

# PATENT SPECIFICATION

DRAWINGS ATTACHED

955,559

955,559



Date of Application and filing Complete Specification Aug. 31, 1961.

No. 31417/61.

Application made in United States of America (No. 89896) on Jan. 19, 1961.

Complete Specification Published April 15, 1964.

© Crown Copyright 1964.

Index at acceptance: —G3 TA5X; G5 J45; H2 A(1B1, 1B2A, 1B2C, 1B2J, 1B2K, 1B2M)

International Classification: —G 04 c (G 10 g, H 02 k)

## COMPLETE SPECIFICATION

### Improvements in or relating to Electronically-controlled Timepieces and Tuning Fork Structures therefor

5 We, BULOVA WATCH COMPANY, INC., a corporation organized under the laws of the State of New York, one of the United States of America, of Bulova Park, Flushing, City and State of New York, United States of America, do hereby declare the invention, for which we pray that a patent may be granted to us, and the method by which it is to be performed, to be particularly described in and by the following statement:—

10 This invention relates to electronically-controlled timepieces and tuning fork structures therefor.

15 According to the present invention there is provided a tuning fork structure comprising a pair of tines, a connecting base for said tines and a stem integral with said base for mounting said structure on a mounting fixture, the junction of said stem and said base being constricted to provide a resilient spring mounting for said structure, and said stem extending upwardly from said base and being situated between the tines.

20 For a better understanding of the invention and to show how the same may be carried into effect, reference will now, by way of example, be made to the accompanying drawings, in which:—

25 Fig. 1 is a schematic representation, in perspective, of the basic components of an electronic timepiece in accordance with the invention.

30 Fig. 2 shows the electrical circuit diagram of the timepiece.

35 Fig. 3 is a plan view of the electronic watch movement as seen on the dial side of the watch.

Fig. 4 is a plan view of the movement as seen on the gear train side of the watch.

40 Fig. 5 is a separate elevational view of the tuning fork structure.

Fig. 6 is a side view of the tuning fork structure.

Fig. 7 is a separate plan view of the timing regulator. 45

Fig. 8 is a side view of the regulator attached to the cup of the magnetic element.

Fig. 9 is a separate view showing the motion transformer for the timepiece.

Fig. 10 is a plan view showing the two sub-assemblies for mounting the components of the electrical drive system, as seen at the dial side. 50

Fig. 11 shows the rear side of the sub-assembly for accommodating the battery. 55

Fig. 12, A to H, demonstrates the operation of the index mechanism in the motion transformer.

#### GENERAL DESCRIPTION

60 Referring now to the drawings and more particularly to Figs. 1 to 4 the major components of the timepiece are a timekeeping standard constituted by a tuning fork 10 and an electronic drive circuit 11 therefor, a rotary movement of conventional design including a gear train 12 for turning the hands of the timepiece, and a motion transformer including an index wheel 13 operatively intercoupling the fork 10 and the rotary movement 12 and acting to convert the vibratory action of the fork into rotary motion. The tuning fork has no pivots or bearings and its timekeeping action is therefore independent of the effects of friction. 65

70 All of the electrical components of the drive circuit are mounted on two unitized sub-assembly units or modules  $F_1$  and  $F_2$  attached to a disc-shaped metallic pillar plate 14 which may be supported within a watch casing of standard design or within any other type of housing, depending on the use to which the timepiece is put. 80

85 It is to be understood that the timepiece may be employed as a source of rotary motion having a constant rate of rotation. A

device in accordance with the invention may, for example, be used to carry out switching actions at predetermined time intervals, the intervals being of extremely long duration.

5 Since the mechanism is capable of operating for a period of a year or more without replacement of the miniature battery, it is possible by suitable gear trains to effect a switching action at a predetermined instant  
10 of time spaced, say, 9 months, 6 days, 5 hours and 30 minutes after a given starting time. The exceptional accuracy of the device is such that a delayed action of this protracted type is predictable within narrow  
15 limits and may be caused to occur within a few minutes or even seconds of the selected time.

Tuning fork 10 is provided with a pair of flexible tines 15 and 16 interconnected  
20 by a relatively inflexible base 17, the base being provided with an upwardly extending stem 18 secured to the pillar plate by suitable screws 19 and 20. The central area of the pillar plate is cut out to permit unobstructed vibration of the tines.  
25

The tuning fork is actuated by means of a first transducer  $T_1$  constituted by a magnetic element 21 secured to the free end of  
30 tine 15, the element co-acting with a drive coil 22, and a phase sensing coil 23. Drive coil 22 is wound on an open-ended tubular carrier 24 affixed to a subassembly mounting form  $F_1$  which is secured to pillar plate 14. Coils 22 and 23 may be wound in juxtaposed relation on carrier 24 or the phase  
35 sensing coil 23 may be wound over drive coil 22.

A second transducer  $T_2$  is provided constituted by a magnetic element 25 secured  
40 to the free end of tine 16 and co-acting with a drive coil 26 wound on a tubular carrier 27.

In a practical embodiment the two transducer coil structures are 0.15 inches long  
45 and 0.18 inches in diameter. Drive coil 26 of transducer  $T_2$  has about 8000 turns of .0006 inch wire, whereas in transducer  $T_1$  drive coil 22 has about 6000 turns and phase sensing coil about 2000 turns of the  
50 same wire. Thus the two transducers bear the same number of turns.

#### THE TRANSDUCER CONSTRUCTION

The two transducers  $T_1$  and  $T_2$  are of like design except that an additional coil is  
55 provided in transducer  $T_1$ . The construction and behavior of the transducers are similar to that of a dynamic speaker of the permanent magnet type with the moving element being the magnet and not the coil.  
60

As shown for transducer  $T_1$  in Figs. 5 and 6, the magnetic element 21 is constituted by a cylindrical cup 21a of magnetic material, such as iron, and a permanent magnet rod 21b coaxially mounted therein. The magnet 21b,

which may be made for example of Alnico, 65 is supported on the end wall of the cup to provide a magnetic circuit in which the lines of magnetic flux extend across the annular air gap 21c defined by the space between the inner magnet and the surrounding  
70 cylinder. The magnet 21b is tapered to assume a frusto-conical shape, whereby the cross-sectional area of the air gap at the mouth of the cup is relatively large.

As best seen in Fig. 6, cylindrical cup 21a is cut out longitudinally along diametrically opposed planes to form slots 21d and 21e. This effects a substantial reduction in the transducer dimension with relatively little flux leakage. The cutouts act to reduce the space occupied by the cups in depth within the casing and make possible a more compact construction of the timepiece. The slots also prevent so-called "dash pot" effects resulting from air compression of the magnet and cup assembly. Such damping is avoided by the slot openings and also by the openings in the tubular carrier.  
80  
85

It will be seen that fixed carrier 23 for supporting the drive coil 22 is horn shaped and is dimensioned to complement the tapered magnet 21b. The carrier 23 and the drive coil supported thereon are received within the annular gap 21c and are spaced both from the magnet and the surrounding cylinder, whereby the magnetic element is free to reciprocate axially relative to the fixed coil.  
90  
95

It will also be noted that the coil 22 wound about carrier 23 is tapered in cross-section so that the greatest number of turns is concentrated at the mouth of the air gap 21c, the least number of turns being located well within the interior of the magnetic element. Since the magnetomotive force produced by the transducer at the fixed frequency and amplitude is the product of coil turns multiplied by flux density, optimum results are obtained by the structure shown herein, where the greatest number of turns is found at the point of maximum flux density.  
100  
105

In operation, an energizing pulse applied to the drive coils of the transducer will cause an axial thrust on the associated magnetic element in a direction determined by the polarity of the pulse in relation to the polarization of the permanent magnet and to an extent depending on the energy of the pulse. Since the magnetic element is attached to a  
110  
115  
120  
tine of the tuning fork, the thrust on the element acts mechanically to excite the fork into vibration.

The vibratory action of the fork and the concomitant movement of the magnetic element induces a back emf in the drive coil, and in the case of the transducer  $T_2$ , in the phase-sensing coil as well. Since the magnetic element reciprocates in accordance with the vibratory motion of the tuning fork,  
125

the back emf will take the form of an alternating voltage whose frequency corresponds to that of the fork.

5 Three functions are served by the transducers. They drive the tuning fork by converting pulses of current delivered to the coils to mechanical pulses. They control the amplitude of the tuning fork by sensing the alternating voltage induced during each cycle, and they control the instant during the cycle when the driving pulse is to be delivered to the coils.

#### TUNING FORK STRUCTURE

15 T tuning fork is a high "Q" mechanical oscillator and will vibrate at a natural frequency determined by the dimensions of the tines and the loading thereon which, in this instance, is determined by the mass of magnetic elements attached to the free ends. The rate at which the timepiece movement is driven is directly proportional to the operating frequency of the vibrator, so that the accuracy of the timepiece may be regulated by predetermining the operative frequency of the tuning fork. In practice, a fork vibrating at 360 cycles per second may be used.

For reasons which will be explained hereinafter, the design of the fork is made such as to provide a constriction 18a of reduced section between the stem 18 and the base 17 of the fork. This reduction in mass between the stem and the base of the fork weakens the connection between the fork mounting and the fork tines and provides in effect a flat spring hinge. The flat spring hinge is of sufficient stiffness to maintain the proper alignment of the fork and yet to elastically mount the fork within the watch casing. Each tine 15 and 16 is also provided at its root with a constriction 15a and 16a, respectively, which may be filed to make small adjustments in tine frequency. To economize on space by allowing room within the casing for the electrical energy source provided by a miniature battery cell 30, the intermediate portion 15b of tine 15 is bowed inwardly, the arc of the bow being concentric with the circumference of the circular battery wafer. To effect symmetry, the intermediate portion 16b of the other tine is likewise bowed, whereby the fork has a knock-kneed appearance.

We shall now consider the reasons for elastically mounting the tuning fork within the casing.

60 Mechanical oscillators for timekeeping purposes require very stable masses and elasticities. Whether this mechanical oscillator consists of more than two masses elastically coupled in a given frequency range is not important as long as the masses and elasticities remain constant.

The pendulum, balance wheel and reed are two-mass oscillators in which the second mass

or inertia is many times and at least "Q" 65 times greater than the first mass. Hence this second mass or inertia, in spite of being unstable, cannot have more influence on the frequency and power of the oscillator than is already determined by the "Q" of this two-mass oscillator. 70

Quartz crystals, vibratory rods and tuning forks are three-mass oscillators, the third mass being the mounting fixture for the oscillator. This third mass or fixture is unwanted, for it is not constant, particularly in portable devices, such as watches. The fixture mass is also a more or less energy-absorbing element when in touch with non-metallic parts or when only lightly in contact with other parts. 75

It may readily be shown that these three-mass oscillators are not as effective as timekeepers when constructed as two-mass oscillators. In a quartz crystal, with its "Q" of one million, if we assume a 2/10 gram oscillating quartz mass, the fixture mass should be at least 400 pounds; the same being true for the vibratory rod. But in the present instance involving a tuning fork in a watch, with a tuning fork having a 0.5 gram mass and a "Q" of 3,000, the wrist watch case and pillar plate would have to weigh at least three pounds. Obviously this is not feasible. 85

In a three-mass oscillator, the sum of three vectors of velocity multiplied by mass and angle velocity times inertia must be zero. In order to bring the fixture vector to zero one must make the other two equal and opposite. In the present tuning fork construction this is substantially accomplished by so connecting the magnetic elements to the parallel tines so that the tines point to the center of gravity of the magnetic elements whereby the velocity vectors of both elements fall into the same line. 90

However, to make the absolute values of velocity times mass equal requires that the natural frequencies of the tines be equal. How accurate this matching of tine frequencies must be depends upon the ratio of the fixture inertia to the inertia of the magnetic element at the foot of the tine. Putting the watch on a hard surface like a glass plate might cause this ratio to exceed 100,000 to 1, so that the frequencies of the tines would then have to be matched accordingly, which means matched to one second. Even with this high matching of the frequencies, we would still have unequal magnet vectors, for the "Q" of the fork is only 3,000. 100

Since the fork is driven on both sides while power is taken off by the ratchet system from the tine which is driven 25% more (tine 16 in Fig. 1), the mathematical "Q" 105 responsible for such balancing can be estimated to about 10,000 so that it would not be sensible to match the tines more accurately than 10 seconds. In this case, the fixture 120

125

inertia ratio would still have to be less than 10,000 to 1, which is not possible when for example the watch is laid on a hard surface.

5 The only practical way to permit the magnets, independently of fixture inertia, to oscillate with equal products of velocity times mass is to mount the entire fork elastically within the watch casing in the manner disclosed above.

10 The resulting natural frequency of the fork will be the arithmetic mean of the two tine frequencies. Theoretically, the mounting elasticity can be "Q" times stiffer or the 15 tine frequency difference ratio times stiffer than the elasticity of one tine, which of these two numbers is smaller. In practice, the elastic mounting is made much less stiff than this theoretical value in order to have 20 more tolerance in unbalance of the tines frequencies. The sensitivity of the watch to shock is not markedly affected by this elastic mounting.

25 The torsional elasticity in the base of the fork takes care of the adverse effect arising when the watch casing is resting on a hard surface. The torsional elasticity is in effect produced by the short tine or stem 18 30 which couples the fixture of pillar plate 14 to the base 17 of the fork. It is to be noted that the stem mounting is very stiff in the plane normal to the plane of vibration.

#### TUNING FORK REGULATOR

35 As is well known, the tines of a vibrating fork normally oscillate toward and away from each other. That is, inward movement of one tine from its normal rest position is accompanied by a corresponding inward movement 40 of the other tine and outward movement of one tine is accompanied by a corresponding outward movement of the other tine.

45 Although it is possible to manufacture tuning forks with a very small margin of error, in large-scale production techniques it is still necessary as a practical matter to effect a final factory adjustment. Also adjustments are required to take care of differences arising from the personal habits of a wearer. 50 In the present instance, the frequency of the fork is determined not by the fork per se but by the combined mass of the tines and their associated magnetic elements and to effect matching of the tines it is necessary that symmetry exist as between the centers 55 of gravity of the two oscillating masses with respect to the axis of symmetry of the fork. Also with aging of the fork over a period of years, a further slight adjustment may be necessary if one wishes to maintain the 60 accuracy of the timepiece within a few seconds a week.

For the purpose of effecting a fine adjustment in operating frequency of each tine, there are attached to the magnetic elements

21 and 25, identical regulator devices 31 65 and 32, respectively. As shown separately in Figs. 7 and 8, regulator 31 is constituted by a flat metal clip preferably made of beryllium copper alloy Beraloy and having a pair of spring fingers 31a and 31b which 70 clamp about a rivet 31c inserted centrally at the end of the associated magnetic cup, the clip lying against the base of the cup. The spring fingers project from a bridge 31d 75 whose arcuate upper edge is serrated to define a series of spaced teeth  $t_1, t_2, t_3$ , etc. By the use of a simple tool adapted to engage the teeth, the clip may be turned in either direction relative to the axis of the rivet to effect an angular displacement of the teeth. 80

The regulator clip in combination with its associated magnetic element constitutes a mass which loads the tine to which they are attached. The frequency of a tuning fork is dependent upon the "effective" length of 85 the tines. Moving the regulators upward, away from the base of the fork, will effectively lengthen the tine by moving its center of gravity. This will cause a slower rate. Conversely, moving a regulator down, toward 90 the base of the fork, will cause a faster rate.

Each tooth  $t_1$ , etc., constitutes a minute component of the total mass, and as the clip is rotated, the resultant displacement in the center of gravity produces a fine change in the operating frequency. In practice, the clip may be designed so that an angular displacement of the clip corresponding to one tooth 95 or groove between causes a two second per day variation in the operating rate of the timepiece. Corrections as small as 1/2 second a day can be easily made by moving the regulator one quarter of a division. Because 100 of the basic accuracy of a tuning fork, corrections greater than a few seconds per day are not required. In fact, the total range in the regulator system shown is only 28 seconds per day. 105

#### THE MOTION TRANSFORMER

110 The vibratory motion of the tuning fork is converted by a motion transformer into rotary motion. This transformer is constituted by a ratchet and pawl mechanism operated by the tuning fork to drive index wheel 13. 115 This wheel in a working embodiment has a large number of teeth (300) and a diameter of only 95/1000 of an inch, the length of each tooth being 8/10,000 of an inch.

The exact operation of the indexing mechanism must be understood in order to appreciate the reliability of the entire mechanism. Obviously, because of motions, shock, and 120 other environmental effects, it is not practical to maintain an exact amplitude for the vibrations of the tuning fork. The following discussion will show that it is not necessary. 125

Fig. 9 is a very much magnified view of

the relationship between the index wheel 13 and the two jewels in contact therewith. The index wheel 13 acts as the actuator for the rotary movement 12 and it is therefore essential that this wheel be advanced by vibratory fork at a constant rate. This is effected by means of an index finger 33, as best seen in Figs. 4, 5, 6 and 9 which is soldered or otherwise attached to a post 34 secured at one end to tinc 15, post 34 having a constriction 34a therein to provide a bending neck.

The index finger is in the form of a light leaf spring and carries a tip 35 which may be a precious or semi-precious stone, such as sapphire. The tip engages the teeth of index wheel 13 so that the oscillations of the tine transmit turning impulses to the wheel. The shaft of the wheel is provided with a pinion which intermeshes with the first gear in the gear train 12.

Operating in conjunction with index wheel 13 is a pawl 36 whose design is similar to that of the index finger, the pawl being secured to an arm 37 pivotally attached to the pillar plate. The position of arm 37 may be adjusted by means of a cam member 38 and locked by locking screw 39. Arm 37 pivots about screw 40.

The index finger and pawl are both tensioned downwardly, the jewelled tips thereof being parallel with the teeth of the index wheel. The tension is such that when the finger is retracted, there is sufficient reverse torque to cause the wheel to reverse direction. This back-up, however, is arrested by the pawl which is phased several teeth plus one-half tooth from the finger and is positioned in advance thereof in the direction of wheel rotation.

It would not be practical to maintain an exact amplitude for vibrations of the tuning fork in a wrist timepiece and the operation of the motion transformer is such that this is not necessary.

It will be noted that the spring forces on the index jewel 35 and pawl 36 not only hold them in firm contact with the index wheel 13 but they also exert a torque on this wheel, in the direction opposite to its forward motion. This torque causes the index wheel to back up during the first portion of the return stroke of the index jewel, until it is engaged by the pawl jewel. This torque is the result of the geometry of the system and is similar to the "draw" in a conventional escapement which tends to hold the pallet fork against the banking pin.

Fig. 12 is a diagrammatic representation of what is happening in the index mechanism when the fork is oscillating. At rest (Fig. 12A), the pawl is against one of the teeth (because of the "draw" effect described above) and the index jewel is located several teeth

away, in a position halfway between two of the teeth.

Let us now look at what happens when the fork vibrates at various amplitudes. And for the purpose of simplicity, let us use the distance between teeth as a measure of this amplitude.

Figs. 12B and 12C show a complete cycle of oscillation at an amplitude of one tooth (from 1/2 tooth right to 1/2 tooth left of the rest position). Note that in going to the right 1/2 tooth, the index jewel picks up another tooth, and on its return stroke to the left it drives the wheel far enough for the pawl jewel to drop off the end of tooth #2, so that we have achieved a movement of one tooth. You can see that further oscillations at the one-tooth level of amplitude would pick exactly one tooth per cycle.

Now let us look at Figs. 12D, 12E and 12F to see what happens when we increase the amplitude to two teeth (one tooth to the left and one tooth to the right of the rest position). Note that the index jewel, in going one tooth to the right, drops off tooth #7, and goes halfway along tooth #8. On the return stroke, however, the first half tooth of travel accomplishes no movement of the index wheel, since the index jewel does not begin to drive the wheel until it strikes tooth #7. Also note that in Fig. 12E, tooth #2 passes beyond the pawl jewel; but after the start of the return stroke the "draw" effect exerts force on the wheel to bring it back 1/2 tooth to the position shown in Fig. 12F. Thus, even with a two-tooth amplitude, we have achieved only one tooth rotation per cycle of oscillation.

Figs. 12G and 12H show the effect of a three-tooth amplitude. Note that the index jewel, in going to the right 1-1/2 teeth, picks up tooth #8. At the other end of the stroke it has moved tooth #8 into the position where tooth #5 was. The pawl jewel has dropped off the end of tooth #4, and so we have achieved a three-tooth advance.

It can be seen that for any amplitude from just over one tooth to just under three teeth, the index wheel advances one tooth for each vibration of the tuning fork. When the total travel of the index jewel reaches three teeth on the index wheel, this wheel advances more than one tooth for each tuning fork vibration; in fact, it advances three teeth, and under conditions where the tuning fork reached such an amplitude the hands would advance at three times their proper rate.

This demonstration has proven that the index mechanism permits wide variations in tuning fork amplitude before the timepiece hands fail to advance in exact synchronism with the vibrations of the tuning fork. It must be realized that the diagrams are greatly magnified. Actually, in practice, the index

6 wheel is only 95/1000 of an inch in diameter and it contains 300 teeth. However, in spite of these small dimensions the mechanism functions exactly as you have seen in this  
 5 magnified diagram and experience has shown that this entire system is completely reliable. The fact that the ratchet system is small does not alter in any way the physical principles involved in its operation.

10 It is not, in practice, possible to determine visually whether the phase between the pawl and the index finger is adjusted to be several teeth plus one-half tooth, as previously indicated. The minute size of the teeth is such  
 15 that the optical observation is extremely difficult with the facilities ordinarily available.

20 However, the proper phasing can be determined at the watchmaker's bench by supplying to the watch circuit a voltage less than the ordinary operating voltage of 1.3 volts. A voltage is chosen below one volt at which the amplitude of the tine is just over one tooth. If the watch will then run, this indicates that the adjustment of phasing is correct.  
 25 Vernier adjustment of the phasing is accomplished by rotating cam 38 to cause the pawl bridge 37 to pivot about screw 40.

#### ELECTRONIC DRIVE CIRCUIT AND AMPLITUDE CONTROL

30 The operation of the motion transformer depends upon the tuning fork amplitude remaining within reasonable limits under all conditions of shock, vibration and motion.

35 Let us now consider the properties which the electronic drive circuit must have in order to maintain the tuning fork amplitude within the desired limits. With conventional watches, the slightest movement of the arm on which a wrist watch is worn results in  
 40 a change in the motion of its balance wheel. After a severe disturbance, the balance wheel motion changes greatly and requires many seconds to return to its normal amplitude. This is because the escapement delivers a  
 45 fixed pulse of energy to the balance wheel each time it swings, whether the amplitude happens to be high or low. Furthermore, as the oil dries up and thickens, the balance wheel motion gradually diminishes to the  
 50 point where the watch will no longer provide satisfactory timekeeping accuracy and must be cleaned and re-oiled.

55 As best seen in Figs. 1 and 2, the electronic drive circuit 11 of the tuning fork comprises a transistor 39, the single cell battery 30 and an R-C biasing network constituted by a condenser 40 shunted by a resistor 41. Transistor 39 is provided with base, emitter and collector electrodes represented by letters B, E and C, respectively.  
 60

The base electrode is coupled through the R-C bias network 40—41 to one end of the phase-sensing coil 23, the other end of the coil being connected to one end of the

65 drive coil section 22. Drive coil 26 is connected in a series with drive coil 22 to the collector electrode C of the transistor.

The emitter electrode E is connected to the positive terminal of the battery 30, the negative terminal thereof being connected to the junction of drive coil 22 and phase-sensing coil 23. Thus the battery is connected  
 70 serially through both drive coils 22 and 26 between the emitter and collector electrodes of the transistor, the collector being negative relative to the emitter.  
 75

The transistor is preferably of the Germanium junction type, and the polarity of the battery connection is shown as it exists when the transistor is of the PNP type.  
 80 Obviously for other types of junction and point contact transistors made of such materials as Silicon or Germanium, the battery connections are arranged in accordance with the particular requirements.  
 85

The interaction of the electronic drive circuit and the tuning fork is self-regulating and functions not only to cause the tines to oscillate at their natural frequency, but also to maintain oscillation at a substantially constant amplitude. In practice, the amplitude of oscillation of the tines will be maintained at a substantially constant value or quickly returned to this value in the event of mechanical disturbance. The electrical behavior of this circuit is set out more fully in the above-identified co-pending applications.  
 90  
 95

To prevent the generation of parasitic oscillations, a condenser 42 is connected across the phase-sensing coil 23 through battery 30 and acts effectively to short out parasitic currents, thereby further stabilizing the systems.  
 100

In one practical embodiment of the invention the magnet coil arrangement is so designed that at the proper amplitude of vibration for the tuning fork the voltage induced in the drive coils has a peak value about 10% less than power cell voltage.  
 105  
 110

This is the key to the operation of the amplitude control system. Because of this a 10% increase in amplitude, resulting from a disturbance, would cause the driving current pulses to be reduced to zero and the tuning fork would rapidly return to its proper amplitude. Furthermore, a 10% decrease in the amplitude of the tuning fork would cause the driving current pulses to double and again return the tuning fork very rapidly to the proper amplitude.  
 115  
 120

In principle, it has been shown that the tuning fork amplitude is controlled by converting it into a voltage, which is maintained at a value about 10% below power cell voltage. The battery cell 30 is of a type designed to provide a very constant voltage for approximately 99% of its useful life; hence the tuning fork amplitude remains at its proper  
 125

value. A suitable battery for this purpose is a cell providing 1.3 volts. If the amplitude changes due to a shock, it will return to the proper value within a very small fraction of a second, because of the amplitude control circuit.

#### SUB-ASSEMBLIES

As best seen in Figs. 3, 10 and 11, all of the electrical components are mounted and unitized on sub-assembly forms  $F_1$  and  $F_2$  fabricated of a durable non-conductive synthetic material. Within form  $F_2$  which is mounted adjacent one side of the pillar plate 14 and is shaped as an arcuate hull, there is supported the transistor 39, a dual capacitor containing condensers 40 and 42 and the resistor 41, the connections therebetween and to the drive coil being made through terminal strip 43.

Adjacent the other side of the base plate there is mounted the form  $F_1$  which is shaped to receive the battery 30 and is provided with a terminal plate 44 on the bottom. Connections between the two forms are made by leads 45. The forms are essentially module units and they can be removed and replaced as separate units.

Thus the tuning fork structure and the gear works operated thereby are centered on the pillar plate, and the electronic drive circuit is mounted on either side thereof to provide a compact, unitized and efficient arrangement which may be readily assembled after the subassemblies are put together and wired.

The reasons a timepiece in accordance with the invention is superior to conventional mechanical and electric timepieces in accuracy and general performance may be summarized as follows:

(1) Because the device uses the vibrations of a precision tuning fork rather than the oscillations of a balance wheel as its basis of time measurement, the device is virtually unaffected by such factors as wearer habits, position error and isochronal error.

(2) The timekeeping ability of the present device is independent of lubrication; in conventional watches efficient lubrication is vital to such mechanisms as the balance wheel pivots.

(3) The present device has a "floating" gear train free from torque; trains in conventional watches are subject to torque from the mainspring. Because in the present device gears transmit motion only, there is no "pressure" on them, and thus practically no wear on bearings.

(4) The design of the present device, which is modular in concept and which eliminates many moving parts, is inherently more reliable.

#### WHAT WE CLAIM IS:—

1. A tuning fork structure comprising a pair of tines, a connecting base for said tines

and a stem integral with said base for mounting said structure on a mounting fixture, the junction of said stem and said base being constricted to provide a resilient spring mounting for said structure, and said stem extending upwardly from said base and being situated between the tines.

2. A tuning fork structure as claimed in claim 1, in which the stiffness of the spring mounting is sufficient to maintain alignment of said fork structure on said mounting fixture.

3. A tuning fork structure as claimed in claim 1 or 2, forming part of a timepiece having electromagnetically actuated means for energizing the tuning fork structure, and means for coupling the tuning fork structure through a gear train to a time indicator.

4. A tuning fork structure in a timepiece, as claimed in claim 3, in which the energizing means for the structure includes an electrical drive circuit, and a battery, and in which one of the tines of the structure is bowed inwardly to allow room for the battery.

5. A tuning fork structure in combination with a timepiece, as claimed in claim 3, in which the means for energizing the tuning fork structure includes an electromechanical transducer operatively associated with the structure, a direct-voltage source of electrical current for energizing the transducer, and an electronic control circuit including a transistor for controlling the excitation of the transducer.

6. A tuning fork structure as claimed in claim 3 or claim 5, in which the coupling means between the tuning fork structure and the time indicator, includes a resilient finger attached to one tine of the fork and arranged to engage a toothed index wheel, and a pawl also engaging the wheel to prevent reverse rotation thereof.

7. In combination a tuning fork structure as claimed in any one of the preceding claims and a transducer comprising a magnetic element attached to one of said tines and formed by a cylinder having a magnetic rod supported co-axially therein whereby an annular air gap is formed between the rod and the inner surface of the cylinder, and a multi-turn cylindrical coil entered into said air gap, said rod being tapered and said coil being similarly tapered.

8. A combination as claimed in claim 7, in which the cylindrical part of the magnetic element is cup-shaped.

9. A combination as claimed in claim 7 or claim 8, in which the coil is wound about a tapered cylindrical support which is capable of moving telescopically into the annular air gap.

10. A combination as claimed in claim 7 or claim 8 or claim 9, wherein the tuning fork structure is supported on a base mount-

- ing, and the coil being fixedly supported from the base mounting.
- 5 11. An electro-magnetically actuated vibrator comprising a tuning fork structure as claimed in any one of claims 1 to 6, and means for actuating said fork structure including an electro-mechanical transducer having a magnetic element attached to one of said tines, and means to regulate the operating frequency of said fork structure including a member pivotally secured to said element and angularly movable thereon to shift the centre of gravity of the total mass of said element and said member.
- 10 12. An electro-magnetically actuated vibrator as claimed in claim 11, in which said member is in the form of a spring clip having a pair of fingers clamping a rivet attached to the base of the magnetic element and pivotable thereon. 20
13. A vibrator, as set forth in claim 11 or claim 12, wherein each of the tines of the fork is provided with one of said frequency regulator means to effect matching of said tines as well as frequency control. 25
14. A tuning fork structure, substantially as described with reference to the accompanying drawings.

HASELTINE, LAKE & CO.,  
Chartered Patent Agents,  
28, Southampton Buildings,  
Chancery Lane, London, W.C.2,  
Agents for the Applicants.

Fig. 1.

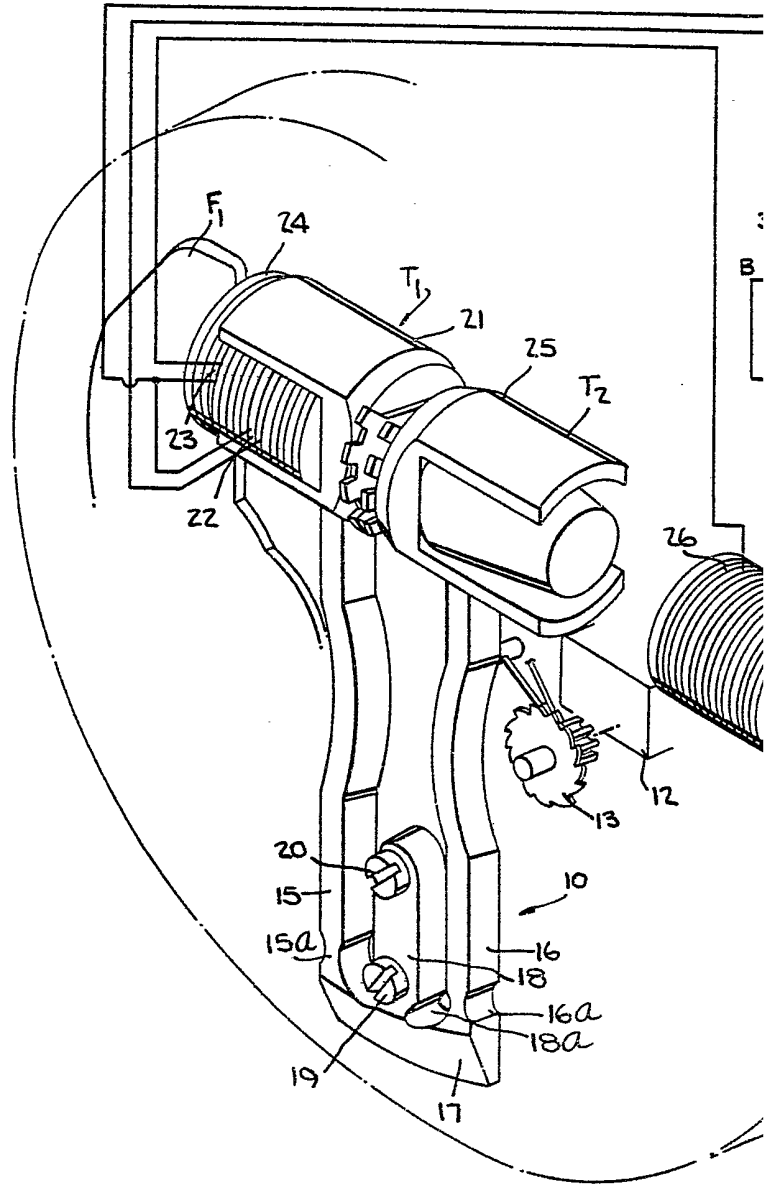

Fig. 1.

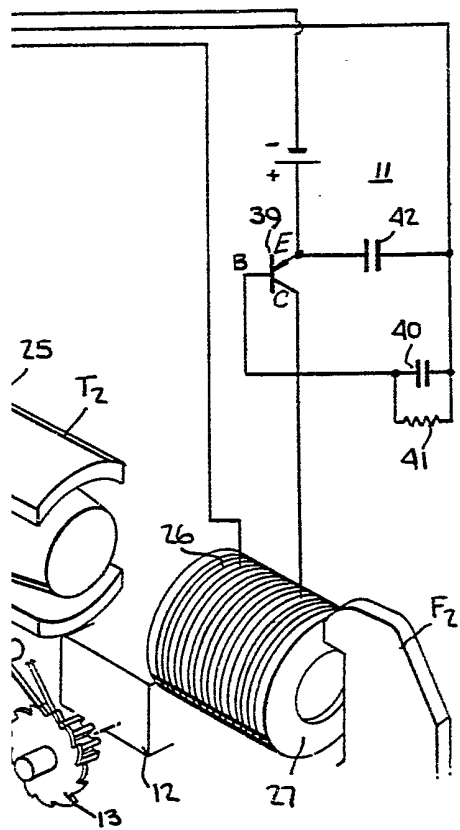

Fig. 2.

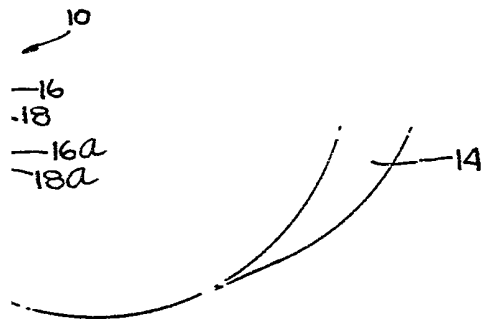
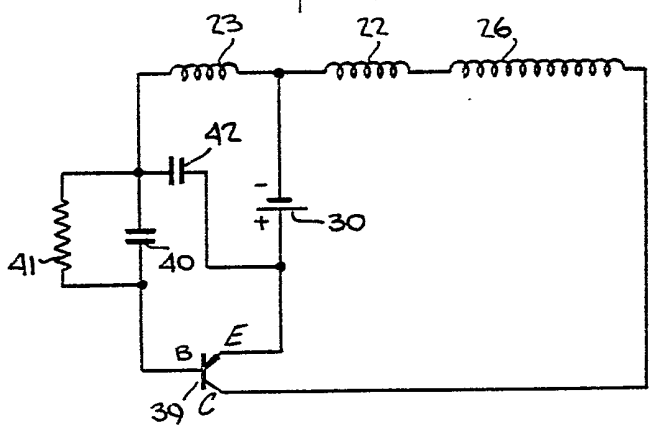

FIG. 1.

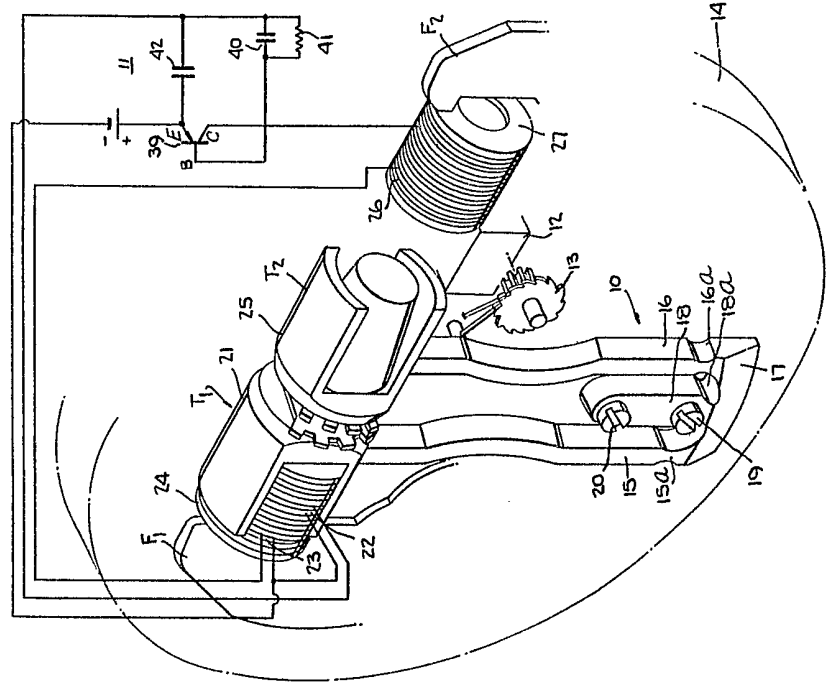
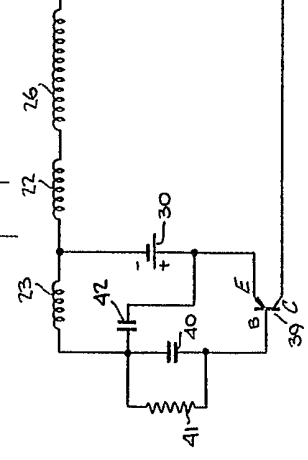
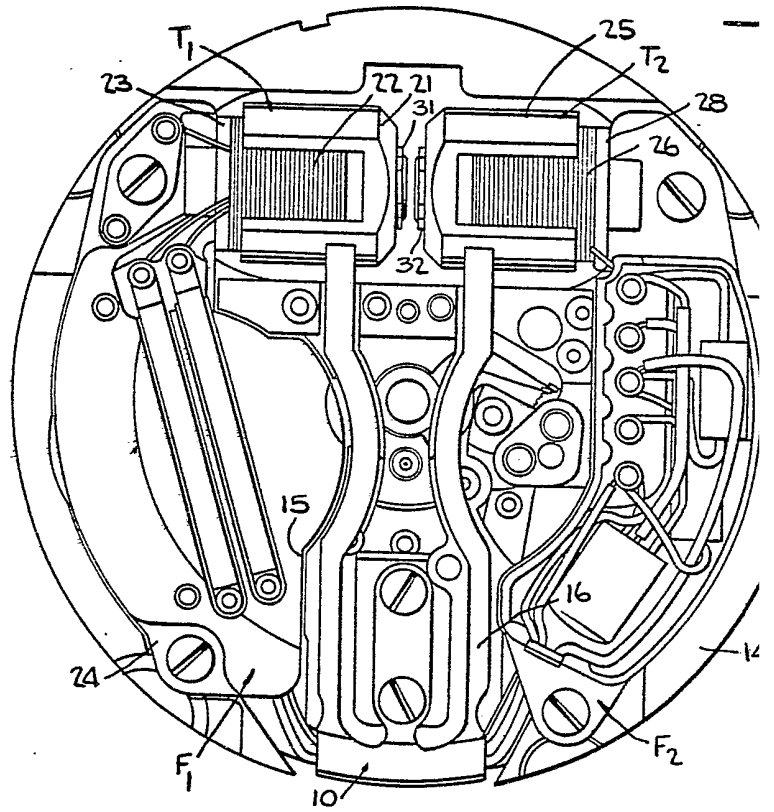

FIG. 2.





955559

COMPLETE SPECIFICATION

4 SHEETS

*This drawing is a reproduction of  
the Original on a reduced scale*

Sheet 2

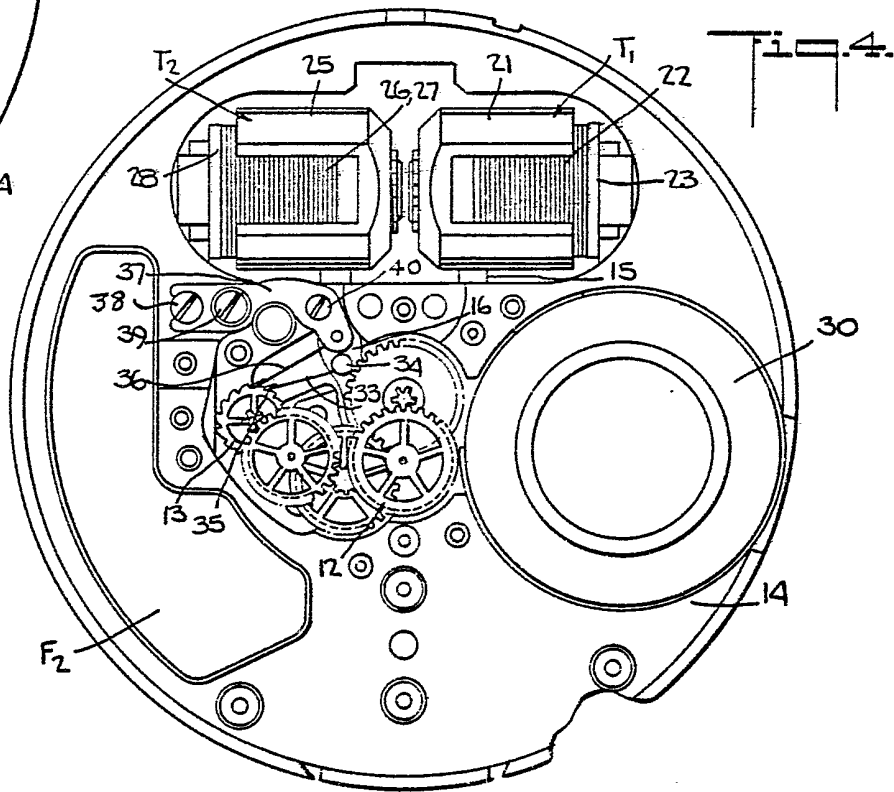
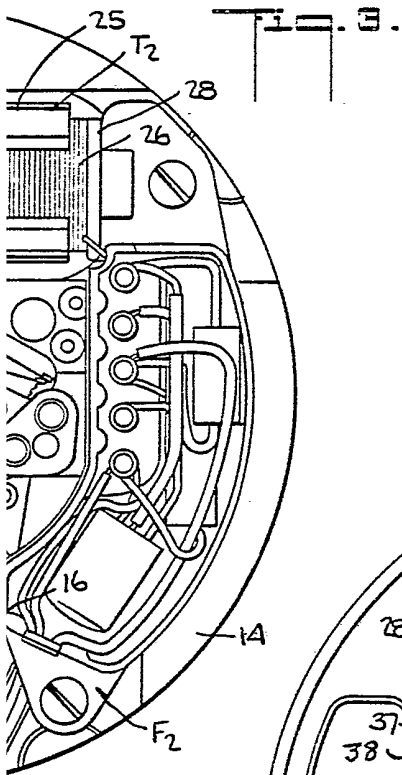

955559

COMPLETE SPECIFICATION

This drawing is a reproduction of  
the Original on a reduced scale

4 SHEETS

Sheet 2

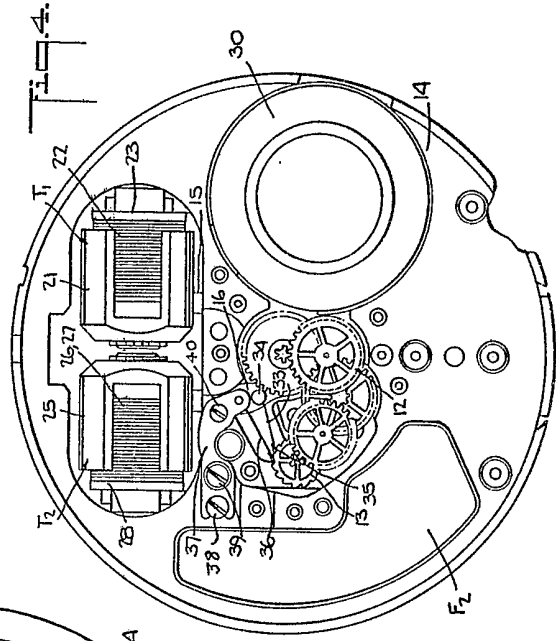
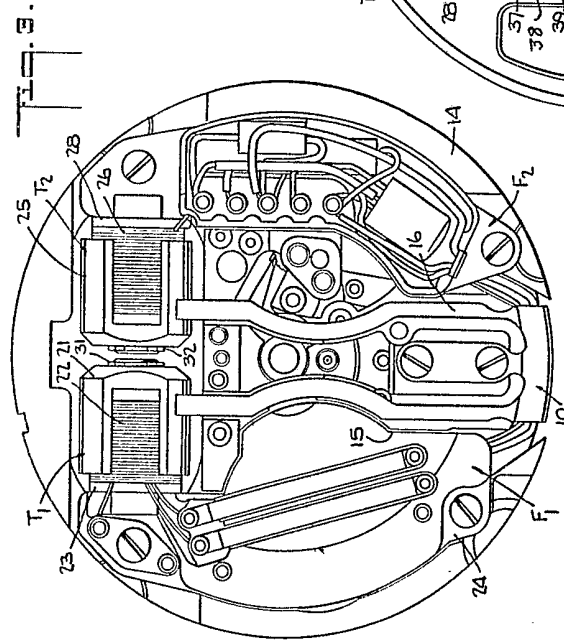

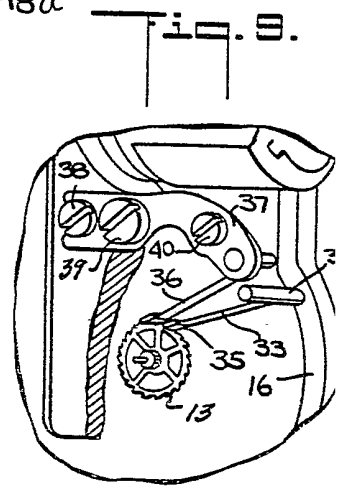
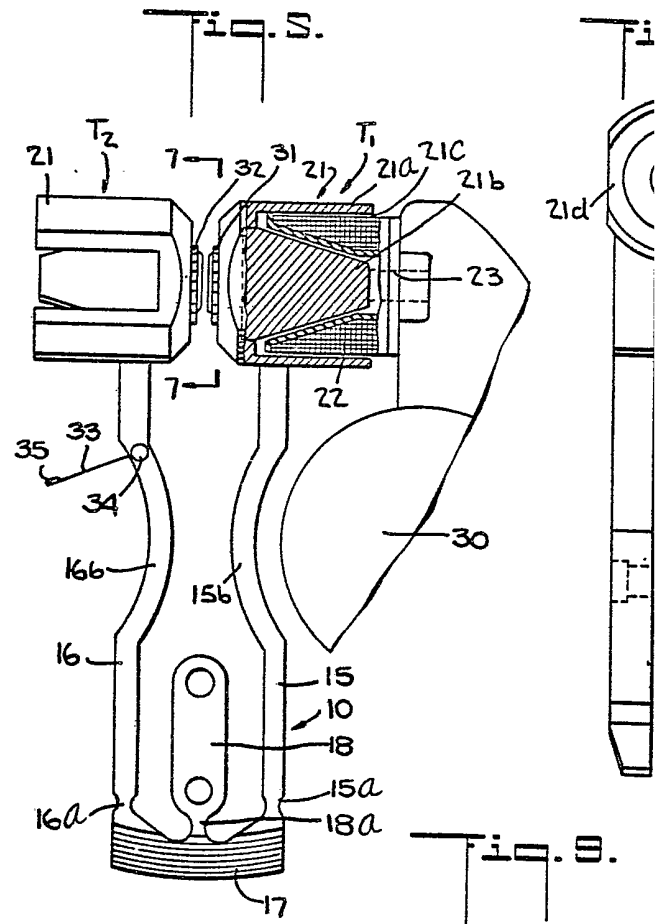

955559

COMPLETE SPECIFICATION

4 SHEETS

This drawing is a reproduction of the Original on a reduced scale

Sheet 3

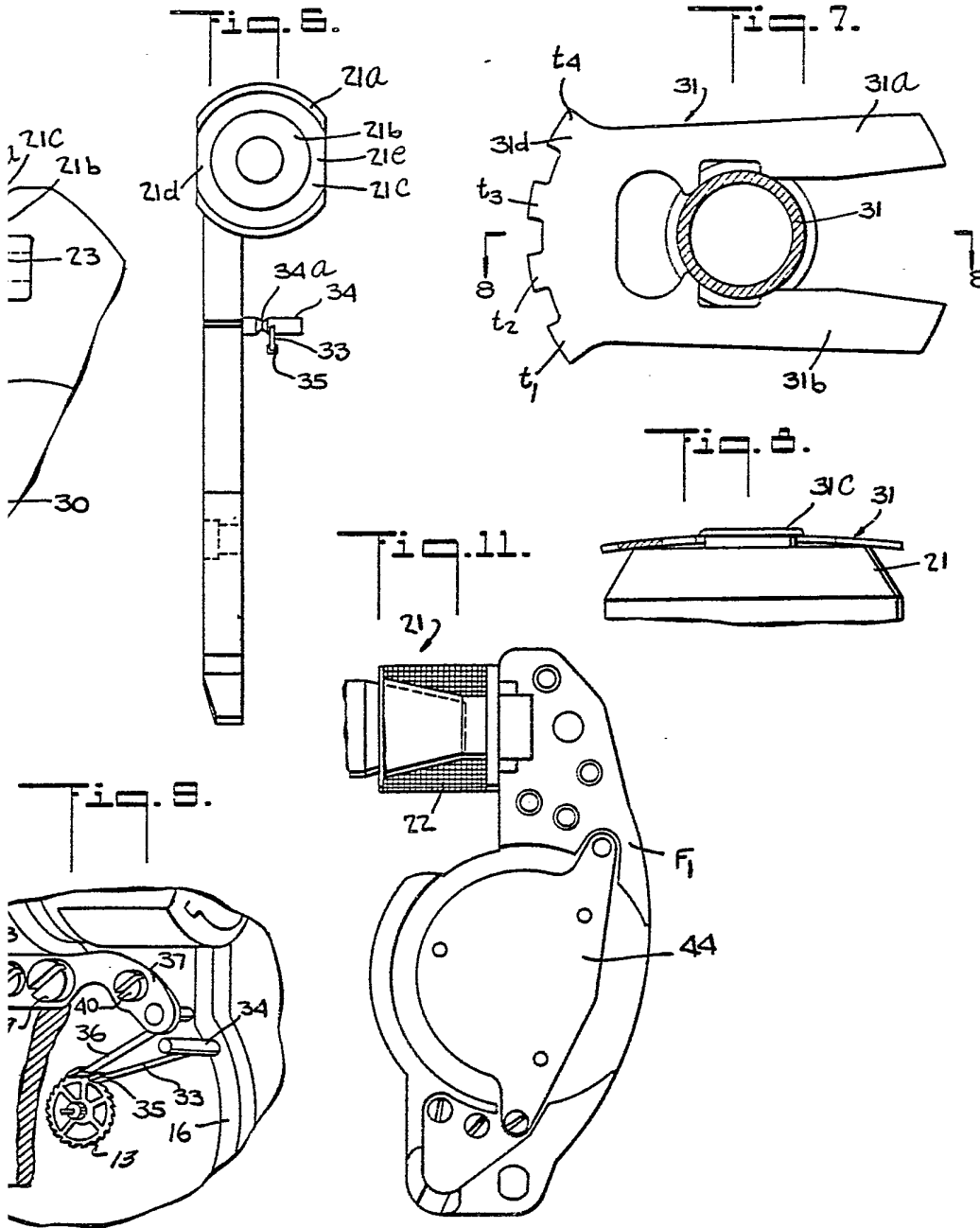

955559

COMPLETE SPECIFICATION

This drawing is a reproduction of  
the Original on a reduced scale  
Sheet 3

4 SHEETS

Sheet 3

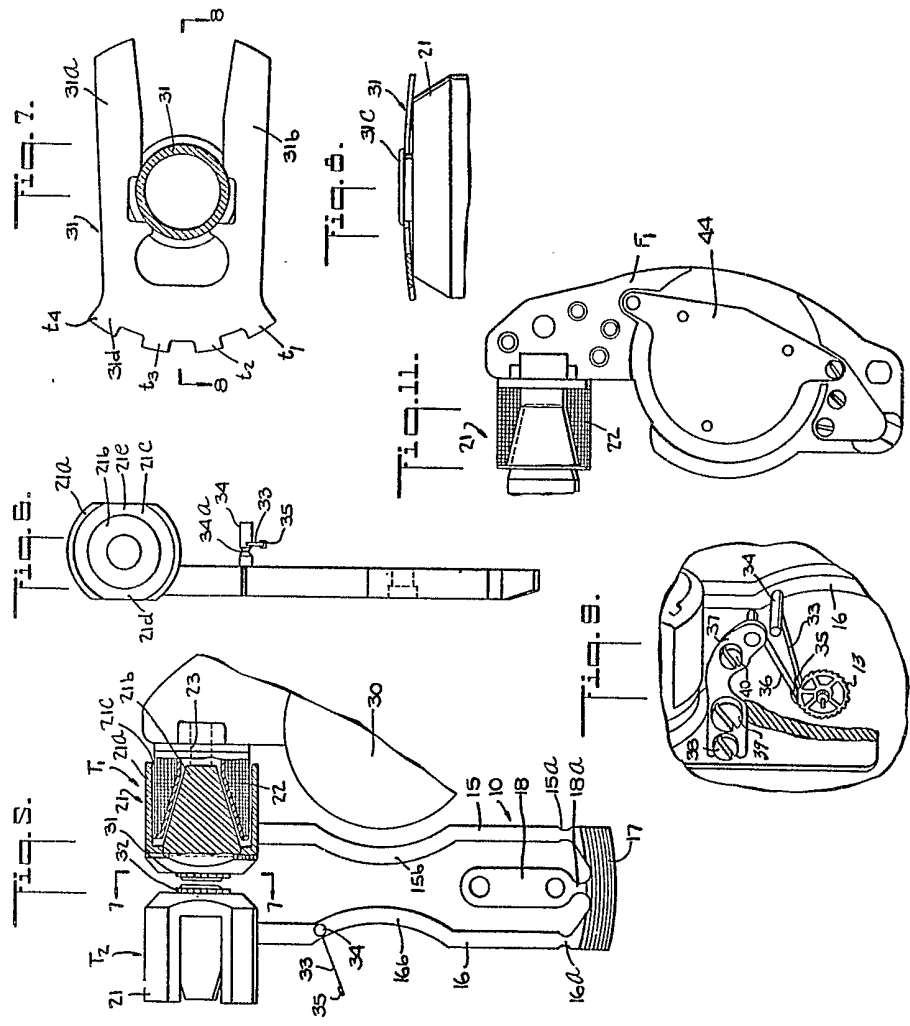
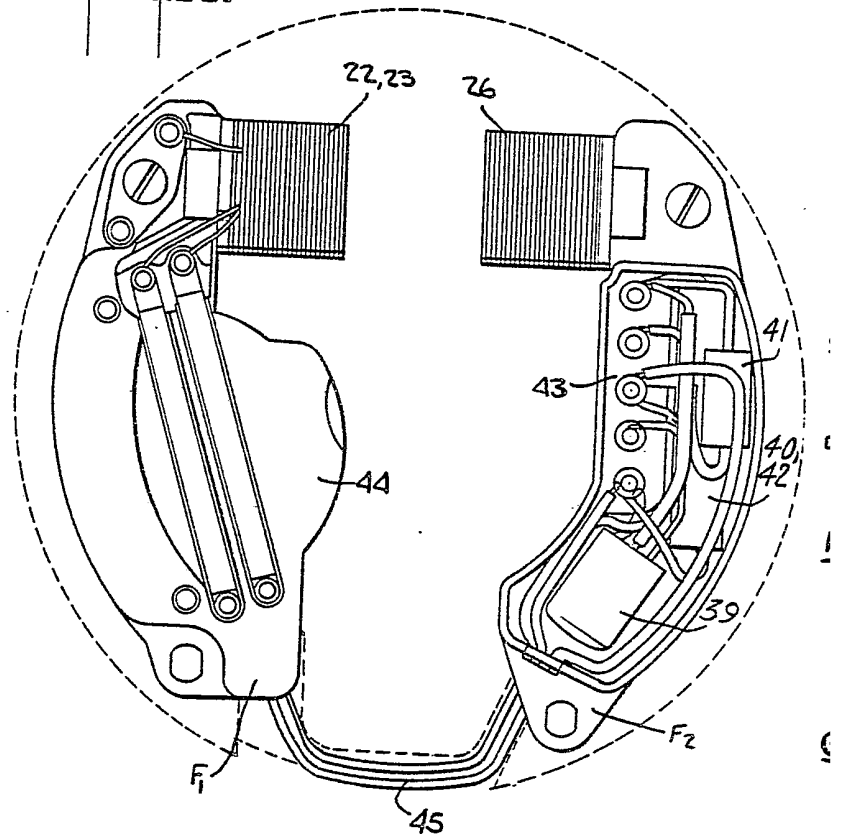

Fig. 12.

Fig. 10.



955559

COMPLETE SPECIFICATION

4 SHEETS

This drawing is a reproduction of the Original on a reduced scale

Sheet 4

Fig. 12.

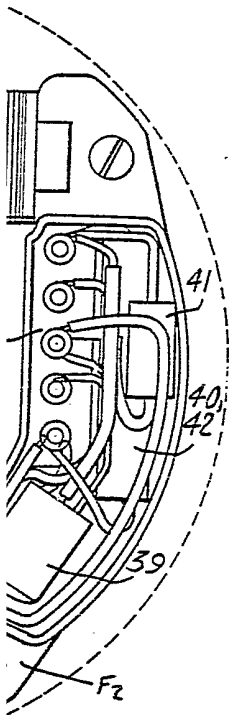
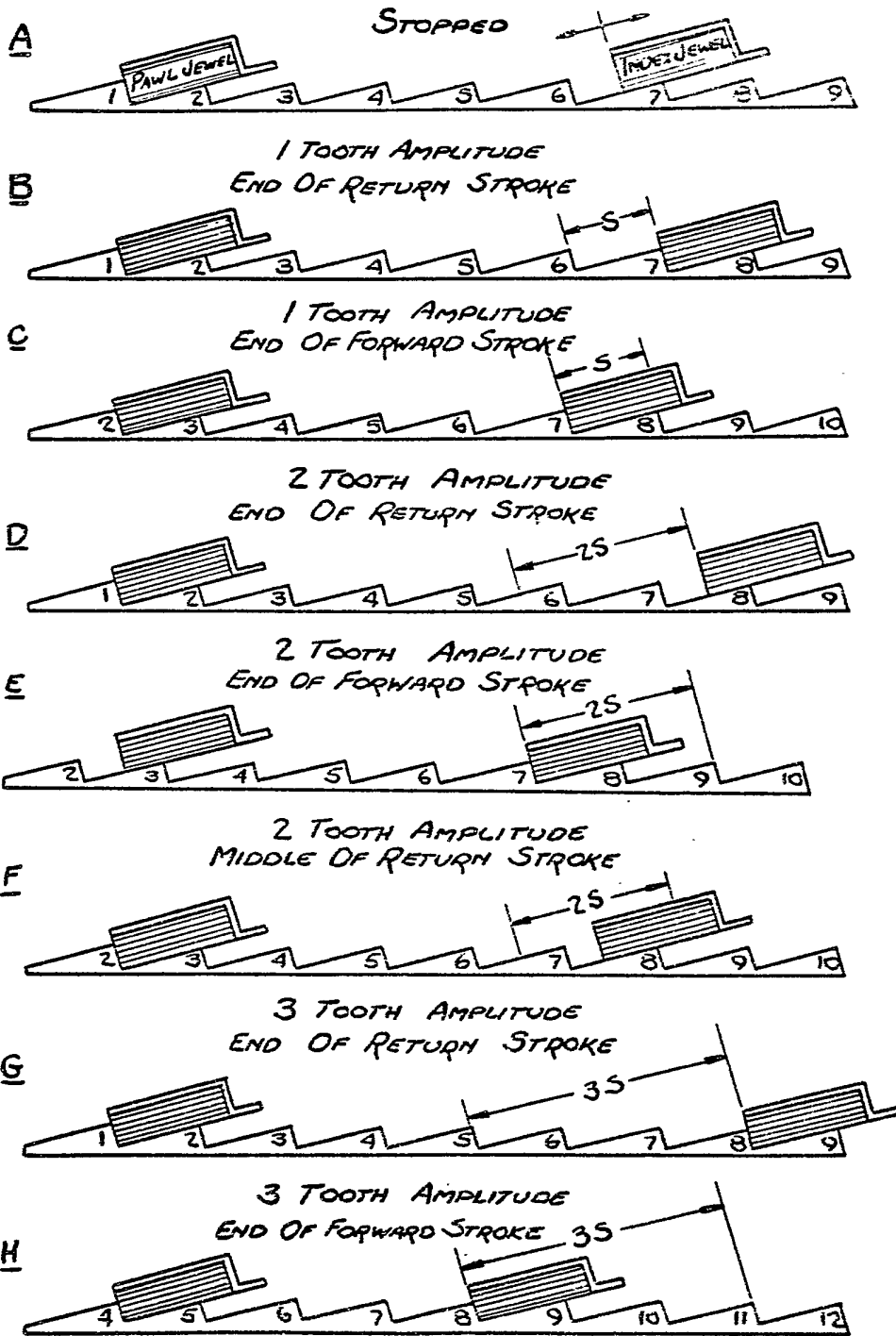

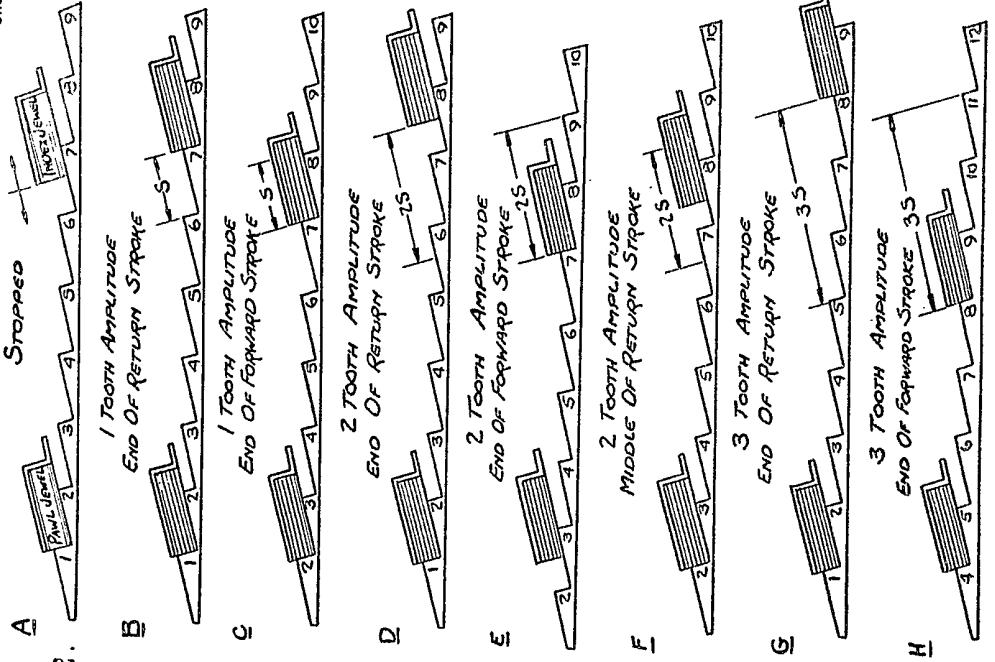

FIG. 12.

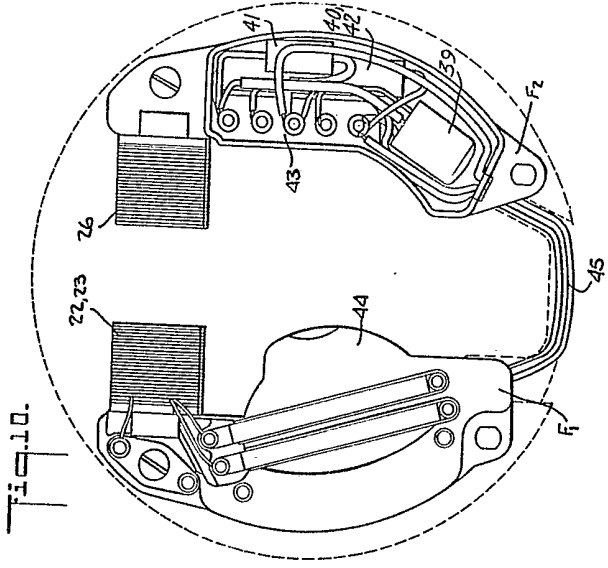

FIG. 10.