

PATENT SPECIFICATION

DRAWINGS ATTACHED

Inventors: WILLIAM OGLE BENNETT and WILLIAM WILSON MUTTER

1,074,104

1,074,104



Date of Application and filing Complete Specification: Feb 2, 1966.

No. 4686/66.

Complete Specification Published: June 28, 1967.

© Crown Copyright 1967.

Index at acceptance: —G3 T(A5X, A7AX); F2 Q(1A2, 1B1, 1B4)

Int. Cl.: —G 04 c 5/00//F 16 d

COMPLETE SPECIFICATION

Improvements in or relating to an Electronic Timepiece

5 We, BULOVA WATCH COMPANY, INC., a corporation organized under the laws of the State of New York, one of the United States of America, of 630 Fifth Avenue, City and State of New York, United States of America, do hereby declare the invention, for which we pray that a patent may be granted to us, and the method by which it is to be performed, to be particularly described in and by the following statement:—

10 This invention relates generally to electronic timepieces wherein the vibratory action of an electronically-actuated tuning fork or other form of high-frequency vibrator is converted into rotary motion by a ratchet and pawl mechanism. More particularly, the invention deals with a stress limiter capable of preventing such mechanisms from being rendered inoperative by reason of shock or other abnormal stress-producing effects.

15 In British Patent Specification No. 854,196 there is disclosed an electronic timepiece including a tuning fork having a relatively high frequency and a battery powered transistorized drive circuit to sustain the vibratory motion of the fork. The reciprocating motion of the fork is transformed into rotary motion by means of a ratchet and pawl mechanism whose drive pawl or index finger is attached to one tine of the work, the pawl engaging and advancing a ratchet wheel which drives a gear train for operating time indicators.

20 In British Patent Specification No. 955559, there is disclosed an improved form of a motion converter in which the ratchet wheel is caused to advance only one tooth for each forward stroke of the index finger attached to the time, regardless of minor variations in the length of the stroke arising from changes in the amplitude of the fork vibration. This is accomplished by means of an auxiliary pawl or click attached to the framework or pillar

plate of the timepiece, the pawl engaging the ratchet wheel at a position relative to the index finger at which the phase between the finger and pawl is several ratchet teeth plus one-half tooth.

25 In British Patent Specification No. 1025165 there is disclosed an electronic timepiece in which index fingers are attached to both tines of a tuning work, which fingers reciprocate in phase opposition and engage and alternately advance a ratchet wheel to provide a balanced operation.

30 The index fingers or pawls used in the various timepieces disclosed in the above-identified patents are usually formed of flat spring material. Under certain abnormal operating conditions, these resilient elements are caused to buckle, and if they are overstressed to a point beyond a critical or limiting strain value, the element will be permanently deformed and the mechanism thereby rendered defective or inoperative.

35 For example, when the timepiece is subjected to a sudden shock, the tine to which the pawl is attached may be caused to swing abruptly toward the ratchet wheel to a significantly greater extent than is ordinarily encountered during normal vibration. On the other hand, because of its inertia, the index wheel will remain approximately in its normal position. The index finger, which extends between a ratchet tooth on the wheel and the point of attachment on the tine, is therefore subjected to an exceptionally heavy stress causing it to buckle. This produces a severe bending of the index finger in the region adjacent the point of attachment to the tine. If the resultant strain imparts a permanent bend to the finger, the pawl will not recover its original form and can no longer engage the ratchet teeth on the wheel. Consequently, the motion of the fork will not be transmitted to the wheel, and the timepiece is inoperative.

[T

According to the present invention there is provided an electronic timepiece having a high-frequency vibrator, a gearworks and a motion transformer intercoupling the high-frequency vibrator and the gearworks to convert the vibratory motion of the high-frequency vibrator into rotary motion to drive the works, the transformer comprising: an index finger attached at one end to the high-frequency vibrator and reciprocating therewith, a ratchet wheel whose teeth are engaged by the other end of the finger to effect turning of the wheel, the wheel being operatively coupled to the gearworks, the finger being caused to bend when the device is subjected a shock imposing a stress on the finger, and a stress limiter to restrict the bending of the finger within a limit preventing permanent deformation thereof.

In order that the invention will be clearly understood and readily carried into effect, the same will now be described in conjunction with the accompanying drawings, wherein:—

Fig. 1 is a perspective view of a tuning fork and motion converter of the type disclosed in the aforementioned Patent Specifications;

Fig. 2 separately shows the motion converter;

Fig. 3A shows the normal relationship of the index finger and the ratchet wheel in the motion converter;

Fig. 3B shows the relationship which arises from excessive stress in abnormal operation;

Fig. 3C shows the permanent deformation resulting from such excessive stress;

Fig. 4 is a stress-strain diagram;

Fig. 5 shows one embodiment of a stress limiter in accordance with the invention;

Fig. 6 illustrates a second embodiment of a stress limiter;

Fig. 7 illustrates a third embodiment of a stress limiter;

Fig. 8 illustrates a fourth embodiment of a stress limiter;

Fig. 9 illustrates a fifth embodiment of a stress limiter;

Fig. 10A illustrates a preferred embodiment of a stress limiter with the index finger in its normal position;

Fig. 10B illustrates the operation of this limiter when the index finger is stressed; and

Fig. 10C shows the recovered position of the index finger when the stress is removed.

55 The Basic Motion Transformed

Referring now to Figs. 1 and 2, there is shown a timepiece of the type disclosed more fully in the above-identified Patent Specifications, including a tuning fork, generally designated by numeral 10, a rotary movement of conventional design including a gear train 11 for turning the hands of the timepiece, and a motion transformer, generally designated by numeral 13, operatively inter-

coupling the fork 10 and the rotary movement 11 and acting to convert the vibratory action of the fork into rotary motion. The tuning fork has no pivots or bearings and its timekeeping action is therefore relatively independent of the effects of friction.

Tuning fork 10 is provided with a pair of flexible tines 14A and 14B interconnected by a relatively inflexible base 15, the base being provided with an upwardly extending stem 16 secured to the pillar plate or the framework by suitable screws. The central area of the pillar plate is cut out to permit unobstructed vibration of the tines.

The tuning fork is electromagnetically actuated through an electronic circuit of the type disclosed in the above-noted patents, including a magnetic element 17 secured to the free end of tine 14A, and a magnetic element 18 secured to the free end of tine 14B. The manner in which the fork or other vibratory member is sustained in vibration forms no part of the present invention.

The vibratory motion of the tuning fork is converted by motion transformer 13 into rotary motion. This transformer is constituted by a ratchet and pawl mechanism operated by the tuning fork to drive an index wheel W having ratchet teeth 19 thereon. In a working embodiment, wheel W is provided with a large number of teeth (300) and a diameter of only $95/1000$ of an inch (22.86×10^{-2} centimeters), the length of each tooth being $8/10,000$ of an inch (20.32×10^{-4} centimeters).

Index wheel W acts as the actuator for rotary movement 11, and it is therefore intended that this wheel be advanced by the vibratory fork at a constant rate. This is effected by means of the main pawl or index finger F, one end of which is secured to a post 20 projecting laterally from tine 14B.

Index finger F is in the form of a light leaf spring and carries a tip 21 which may be of precious or semi-precious stone, such as sapphire. The tip engages the ratchet teeth 19 of index wheel W so that the oscillations of the tine transmit turning impulses to the wheel. The shaft of the wheel is provided with a pinion 22 which intermeshes with the first gear in the gear train 11.

Operating in conjunction with index wheel W is an auxiliary pawl 23 whose design is similar to that of the index finger F, the pawl being secured to an arm 24 pivotally attached to the pillar plate. The position of arm 24 may be adjusted by means of cam member 25 and locked by locking screw 26. Arm 24 pivots about screw 27. In this way the point at which auxiliary pawl 23 engages the wheel W may be adjusted relative to the point of engagement of the index finger.

The index finger and pawl are both tensioned downwardly, the jewelled tips thereof being parallel with the teeth of the in-

65

70

75

80

85

90

95

100

105

110

115

120

125

5 dex wheel. The tension is such that when the
finger is retracted, there is sufficient reverse
torque to cause the wheel to reverse direction.
This back-up, however, is arrested by the
10 pawl which is phased several teeth plus one-
half tooth from the finger and is positioned
in advance thereof in the direction of wheel
rotation. It would not be practical to main-
tain an exact amplitude for vibrations of the
tuning fork in a wrist timepiece and the
operation of the motion transformer is such
that this is not necessary.

15 It will be noted that the spring forces on
the index finger F and pawl 23 not only
hold them in firm contact with the index
wheel W but they also exert a torque on this
wheel, in the direction opposite to its for-
ward motion. This torque causes the index
20 wheel to back up during the first portion
of the return stroke of the index jewel, until
it is engaged by the pawl jewel. This torque
is the result of the geometry of the system
and is similar to the "draw" in a conventional
25 escapement which tends to hold the pallet
fork against the banking pin.

The Effect of Stress on the Motion Transformer

30 The stress limiter in accordance with the
invention is applicable to either or both the
index finger and pawl shown in Figs. 1 and
2, or to any other form of motion trans-
former wherein one or more pawls or index
35 fingers are coupled to a vibratory member
and engage an index wheel or rack device
having ratchet teeth. For purposes of illus-
trating the effect of stress in its simplest
possible form, we shall in Figs. 3A, 3B and
40 3C, consider normal and abnormal conditions
which prevail during operation of tine 14B in
Fig. 1, which is coupled by index finger F to
ratchet wheel W. It will be appreciated, how-
ever, that the invention is not limited to this
application.

45 It will be seen in Fig. 3A that one end
of index finger F is inserted into a hole in post
20 and is held therein by a tapered pin 28.
This hole may in practice be round, square-
shaped, or in any other form. The attach-
ment of the finger to the post may also be
50 accomplished by riveting, welding or any
other known means.

55 The jewelled tip 21 of the finger F is re-
ceived by a ratchet tooth 19 in the wheel W.
In normal operation of the tuning fork, as
the tine 14B swings in the direction toward
index wheel W, the finger tip pushes against
the ratchet tooth to thereby turn the wheel,
and when the tine swings back, the finger
tip is retracted and drops into the next tooth.
60 It will be noted that in normal operation, little
flexing occurs in the finger.

We shall now, in connection with Fig. 3B,
consider an abnormal operation. At the in-
stant of a heavy shock, tine 14B is caused to

65 swing sharply from its initial position, shown
in broken lines, to be position to the left
thereof, shown in solid lines. The index
wheel W, which is coupled to the gear-works,
because of its inertia, does not turn in re-
70 sponse to this blow but remains approxi-
mately at its initial position. As a consequence
of the stress imposed by the tine on one end
of the finger, whose other end is effectively
held by the ratchet wheel, the index finger is
75 forced to buckle or bow outwardly to an
extent determined by the degree of tine
swing. The resultant bending of the finger
is greatest in the region adjacent the point
at which the finger is attached to post 20.

80 In order to appreciate the effect of this
action on the finger, reference is now made
to the stress-strain diagram illustrated in
Fig. 4. Stress is the intensity of force imposed
on a unit area. In the case of index finger F,
85 we are dealing with a stress on an elastic
member resulting from a compressive force
imposed thereon by the tine. Stain is the
measure of the amount of deformation the
finger undergoes when it experiences stress.

90 For spring materials which recover their
form after the stress thereon is released, the
plot of stress (S) versus strain (E) is practi-
cally a straight line. Hence it will be seen
on the diagram that as the compressive stress
is increased, strain is directly proportional to
95 stress. However, above a limiting or critical
value L, which is the limit of proportionality,
the relationship is no longer proportional.
Thus, for stresses up to value L, when the
stress is removed the strained spring will re-
100 turn to its original configuration, but for
stresses above this value, the finger will take
on a permanent set, as shown in Fig. 3C.
As a result, the finger tip no longer lies in
engagement with the ratchet teeth and the
timepiece is rendered inoperative.

105 Measurements on a variety of materials
suitable for index fingers have indicated
that for values E_L , the degree of strain at the
proportional limit varies from approximately
110 0.75% to about 1.5% depending on the
materials being tested. When a straight mem-
ber having a thickness (t) is bent into a
circular shape having a radius (R), the outer-
most surface of the member is strained in
115 tension. Assuming that the neutral axis (the
unstrained plane of the circular shape) is in
the center of the section, it can be readily

demonstrated that the elongation $\frac{(\Delta l)}{l}$ at the
120 outermost surface is expressed by the follow-
ing equation:

$$\frac{\Delta l}{l} (\%) = \frac{t}{2R} \times 100,$$

wherein: l is the length of the finger, t is
the thickness of the finger and R is the radius
of curvature of the bent finger.

In such instances, the neutral axis lies at a radius slightly less than the radius of the center of the section. The thickness of the index finger in one working embodiment of a timepiece is .00055 of an inch (139.70×10^{-5} centimeters). Inserting this value in the above equation, together with the minimum observed value (0.75%) for E_{L_s} , for metals suitable for the index finger, the resulting critical value for R then becomes .037 inch (94×10^{-3} centimeters). Hence, in this specific example, permanent deformation can be avoided if the index finger can be constrained where it emerges from the post to which it is attached so that it cannot, as a result of buckling, bend with a radius of curvature smaller than a radius of .037 inch (94×10^{-3} centimeters).

Forms of the Stress Limiter

Referring now to Figs. 5 to 9, five different versions of a stress limiter in accordance with the invention are shown, each of which acts to restrict the bending of the index finger F in the region where it leaves post 20 to a radius never smaller than R. Such bending, as noted previously, occurs as a result of shock, and the limiter, by constraining the degree of bending prevents permanent deformation of the finger. It is to be noted that the smaller the radius, the greater the curvature of the bend, hence a larger radius avoids deleterious deformation.

In Fig. 5, the stress limiter is in the form of a nose member SL_1 welded or integral with the post 20, from which the index finger F extends, the nose projecting in the direction of the ratchet wheel but having an under-surface which curves away from the linear axis of the finger. This curved surface of the limiter is engaged by the finger, as shown in dotted lines, only when the finger bends outwardly so that the curvature of the finger in the region adjacent the post has a radius the value of which cannot be smaller than the critical radius R at which a permanent deformation occurs.

It will be apparent from Fig. 5, as well as in the succeeding figures, that the same type of stress limiter could be used to prevent inward bending of the index finger as well as outward bending, for the finger is capable of buckling in either direction. In practice, however, it has been found that when the finger buckles inwardly, as a result of heavy shock, the jewel tip is forced over the top of the index wheel teeth, which are very shallow, and therefore straightens out before the buckling is sufficient to bring about a significant bend inwardly at the point of attachment to the post. Hence it is not usually necessary to install a stress limiter on the underside of the finger, although in some instances, this may be desirable.

In Fig. 6, the stress limiter SL_2 is in the

form of a nose, as in Fig. 5, having an extension which wraps about and clamps onto the finger post 20 whereby the limiter may be installed without welding. The operation is otherwise the same as in Fig. 5.

In Fig. 7, the limiter SL_3 takes the form of a curved bar having a straight extension received in the hole in the post 20 and held therein with the index finger by the tapered holding pin. The curvature of this bar is the same as the nose curvature on SL_1 and SL_2 , and serves the same function.

In Fig. 8, limiter SL_4 is a hook-shaped bar whose tip is positioned to arrest further movement of the index finger when the finger assumes the limit of its safe curvature. The bar is held in the post by the pin, as in the case of Fig. 7.

In Fig. 9, limiter SL_5 is merely a pillar which is mounted on the framework of the timepiece at a position to intercept the finger when it assumes the limit of its safe curvature. It is to be noted that the limiter need merely engage the finger at a point thereon, rather than along a portion thereof in order to prevent excessive bending in the region adjacent the point of attachment.

Preferred Form of Stress Limiter

Referring now to Figs. 10A, 10B and 10C, there is shown a preferred embodiment of a stress limiter SL_6 in accordance with the invention. The limiter is constituted by a nearly straight and rigid bar member, one end of which is secured by the holding pin 28 in the post 20 from which the index finger also extends. The length of the member SL_6 is about one-third the active length of the index finger from its point of attachment to the post. The rigid member has a slight bend therein so that it is angularly displaced from the finger and does not touch the finger under normal operating conditions, as shown in Fig. 10A.

When the index finger is bent, as shown in Fig. 10B, in response to a stress-producing shock, it is intercepted by the free end of the rigid member SL_6 at a point preventing the finger from assuming an excess curvature. Thus, when the stress is relieved, the finger straightens out and returns exactly to its previous position, as shown in Fig. 10C. In all instances, therefore, the stress limiter prevents the index finger from bending during shock with a radius less than the minimum established by the physical properties and thickness of the finger material.

WHAT WE CLAIM IS:—

1. In an electronic timepiece having a high frequency vibrator, a gearworks and a motion transformer intercoupling the high frequency vibrator and the gearworks to convert the vibratory motion of the high frequency vibrator into rotary motion to drive the works,

- the transformer comprising: an index finger attached at one end to the high frequency vibrator and reciprocating therewith, a ratchet wheel whose teeth are engaged by the other end of the finger to effect turning of the wheel, the wheel being operatively coupled to the gearworks, the finger being caused to bend when the device is subjected to a shock imposing a stress on the finger, and a stress limiter to restrict the bending of the finger within a limit preventing permanent deformation thereof.
2. In the electronic timepiece as claimed in claim 1, wherein the stress limiter acts to restrict the bending to a radius of curvature which is greater than a predetermined value established by the physical properties and thickness of the finger.
3. In the electronic timepiece as claimed in claim 1 or 2, wherein the index finger is attached to a post forming a point of attachment with said high frequency vibrator, the stress limiter restricting the bending of the finger in the region adjacent to said point of attachment with said post.
4. In the electronic timepiece as set forth in claim 1, 2 or 3, wherein said finger extends from the post forming a point of attachment of said finger with said high frequency vibrator, and said limiter is constituted by a nose member attached to said post and projecting forwardly therefrom toward said ratchet wheel, said nose member having a curved undersurface which is engaged by said bent finger only at said limit of bending of the finger.
5. In the electronic timepiece as set forth in claim 1, 2 or 3, wherein said finger extends from the post forming a point of attachment of said finger with said high frequency vibrator, and said limiter is constituted by a bar attached to said post and projecting forwardly therefrom, the end of said bar being curved to provide an abutment which engages the bent finger at said limit of bending of the finger.
6. In the electronic timepiece as set forth in claim 1, 2 or 3, wherein said limiter is in the form of a substantially straight and rigid bar attached to the post forming a point of attachment of said high frequency vibrator with said finger and extending from the post or point of attachment in the direction of said finger, the forward portion of said bar being bent to provide a stop which engages said finger only when it bends to a degree approaching the said limit of bending of the finger.
7. In an electronic timepiece having an index finger and a stress limiter to restrict the bending of the finger, the stress limiter having its parts constructed, arranged and adapted to operate substantially as hereinbefore described with reference to Fig. 5, Fig. 6, Fig. 7, Fig. 8, Fig. 9 or Figs. 10A, 10B and 10C, and Figs. 1, 2, 3A, 3B, 3C and 4 of the accompanying drawings.

HASELTINE, LAKE & CO.,
Chartered Patent Agents,
28 Southampton Buildings,
Chancery Lane,
London, W.C.2.
Agents for the Applicants.

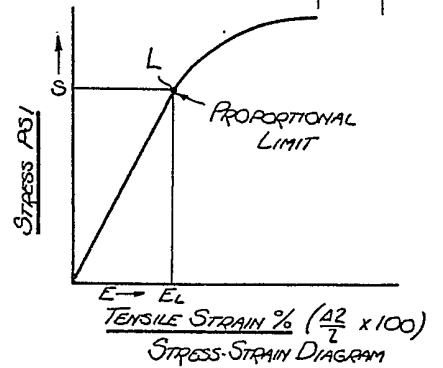
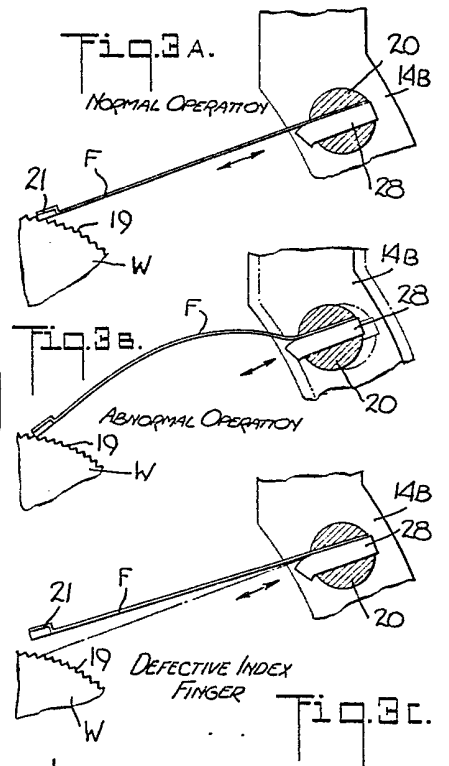
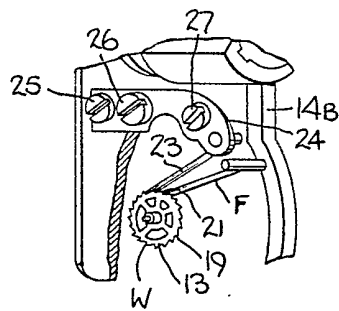
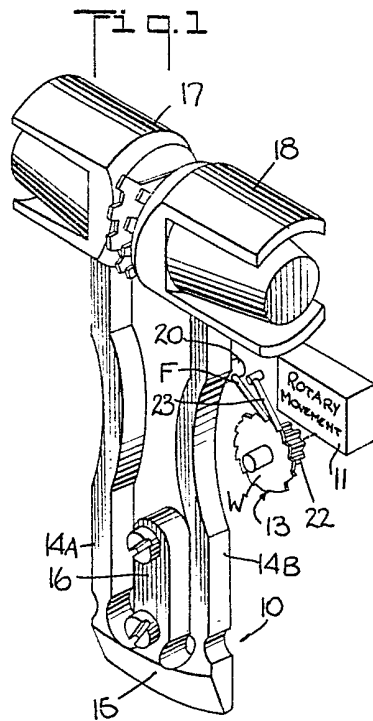

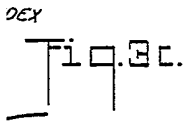
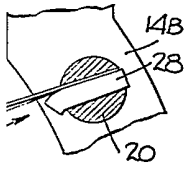
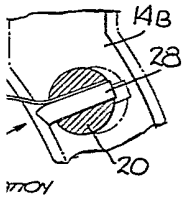
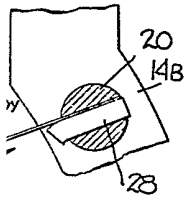

RATIONAL
 UNIT

$\frac{1}{2}$ (42 x 100)
 IN DIAGRAM

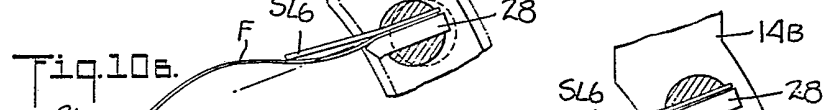
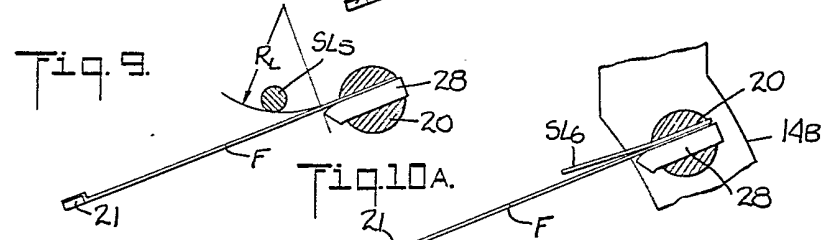
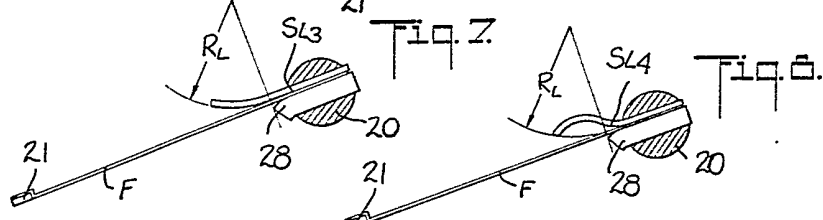
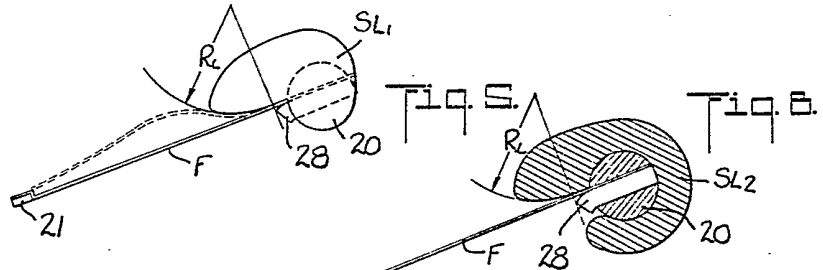

1074104 COMPLETE SPECIFICATION
 This drawing is a reproduction of
 the Original on a reduced scale
 Sheets 1 & 2

