

PATENT SPECIFICATION

(11) 1412340

1 412 340

- (21) Application No. 10999/73 (22) Filed 7 March 1973
- (31) Convention Application No. 3 760 / 72 (32) Filed 15 March 1972 in
- (33) Switzerland (CH)
- (44) Complete Specification published 5 Nov. 1975
- (51) TNT. CL.² GO4F 7/08
- (52) Index at acceptance
G3T A8
- (72) Inventors GERALD DUBOTS
FRANCOIS BERTHOUD



(54) CHRONOGRAPH TIMEPIECE

(71) We, EBAUCHES S.A., a Swiss Body Corporate, of 1, Faubourg de l'Hopital, 2001 Neuchatel, Switzerland, do hereby declare the invention, for which we pray that a patent may be granted to us, and the method by which it is to be performed. to be particularly described in and by the following statement: — This present invention relates to a chronograph time piece.

According to the invention there is provided a chronograph timepiece wherein the chronograph mechanism includes a chronograph gear train arranged to be driven by the gear train of the movement of the timepiece and provided, at its end connected to the gear train of the movement, with a coupling and braking device, working in synchronism and, near its other end, with at least one further braking device, the arrangement being such that, while the chronograph gear train is stopped and is disconnected from the gear train of the movement, the chronograph gear train is held at its respective ends by the braking devices.

The invention will now be further described, by way of example, with reference to the accompanying drawings, in which:—

Figure 1 is a plan view of a movement of a chronograph watch in which only the elements necessary to the understanding of the invention have been shown

Figures 2a and 2b constitute together a sectional view along line II-II of Figure 1, on an enlarged scale

Figure 3 is a sectional view of a detail of Figure 2a, on a still further enlarged scale;

Figure 4 is a plan view of part of the mechanism of the chronograph, in a position different from the one shown in Figure 1, and

Figure 5 is a plan view, from the bottom, of the mechanism of the chronograph in which only the gear train of the chronograph has been shown.

The watch movement shown comprises a chronograph mechanism the frame of which is constituted by two plates 1 and 2 and by several bridges such as 3 and 4. This frame is secured to the base plate of the movement which is not shown in the drawing.

The gear train of the chronograph, which is arranged to be driven by the gear train of the movement of the timepiece, comprises a seconds wheel 5, two intermediary elements 6, 7 and 8. 9. an intermediary wheel 10 and a minute wheel 11 which makes one revolution per 60 seconds, two intermediary elements

12, 13 and 14, 15, an intermediary wheel 16 and an hour wheel 17.

The seconds wheel 5 is coaxial to a shaft 1 carrying a seconds hand which has not been shown. The wheel 5 is driven by the intermediary of a coupling mechanism combined with a braking mechanism which is disclosed hereafter and which forms the subject of the present applicants' Patent No. 1.403,127, ensuring the connection between the wheel 5 and a wheel 19 meshing with the elongated pinion 20 of the third wheel of the gear train of the movement. This wheel 19 is frictionally mounted on a sleeve 21 (Figure 3) constituting a hub. freely mounted on a cannon 22 forced on the shaft 18. The hub 21 is pressed against a shoulder 22cm of the cannon 22 by a spring 23 interposed between the wheel 5 and a shoulder I 8cm of the shaft 18. The shoulder 22cm is provided with a frustoconical seat 24 with which cooperates a bearing surface 25, of corresponding shape, of the end of the hub 21.

Owing to this arrangement, when the mechanism shown is in the engaged position, as shown in the drawings, the wheel 19 is fast with the wheel 5 owing to the axial force exerted by these two wheels on each other under the action of the spring 21: also, the wheel 19 is fast with the cannon 22 and consequently with the shaft 18, owing to the axial force exerted by the wheel 19 and by the cannon 22 on each other, also under the action of the spring 23.

The coupling mechanism shown comprises a control device including a control element 26 constituted by a small circular plate located in a recess of corresponding shape in the plate 2, and able to be moved axially under the effect of the forces exerted thereon by three conical pins 27 disposed at 120° to each other, which pass through holes 28 provided in this small plate and which are carried by a sliding element 29 able to be moved transversely. This sliding element is part of a control mechanism of the chronograph which will be disclosed later. When the pins 27, acting on the edges of the holes 28, lift the small plate 26, the latter lifts the spring 23 and the wheels 5 and 19, so that the axial force exerted by the spring on the shoulder 18a of the shaft 18 ceases, thus disconnecting the wheel 19 from the seconds wheel 5 and from the cannon 22. Moreover, the wheel 5 bears axially against a portion 2a of the plate 2, that brakes it. In this way, the coupling mechanism is combined with

a braking mechanism which brakes the wheel 5 as soon as the gear train of the chronograph is disconnected from the gear train of the movement.

The disconnection of the shaft 18 has for object to permit the resetting of it to zero by means of a heart piece 30, without the wheels of the chronograph being driven.

The minute wheel 11 is frictionally coupled to a shaft 31 carrying a minute hand, which is not shown, through the intermediary of a coupling mechanism comprising a spring 32 interposed between the wheel 11 and a shoulder 31a of the shaft 31 and which presses the wheel 11 against a shoulder 33a of a sleeve frictionally mounted on the shaft 31. A control device including a small plate 34 similar to the small plate 26 of the coupling mechanism which has been disclosed hereabove, also includes a sliding element 35 which controls the plate 34 and which belongs to the control mechanism of the chronograph, disclosed hereafter. This sliding element carries conical pins 36 (Figure 1), acting on the small plate 34 for lifting it axially and permitting it to act on the spring 32 so as to disconnect the shaft 31 from the wheel 11 during the resetting to zero of the shaft, which is effected by means of a heart-piece 37. It is to be noted that, when the chronograph mechanism is merely stopped, without the indicators being returned to zero, the sliding element 35 is not operated while the sliding element 29 is operated alone. Thus the spring 32 is not lifted by the plate 34, and the shaft 31 is not disconnected from the wheel 11. It is only during the return to zero operation, by means of the sliding element 35, that the plate 34 is lifted, producing the disconnection of the shaft 31 from the wheel 11, this wheel being pressed against the edge of the endstone 38 of the upper bearing of the shaft 31. This shaft is then free permitting the return to zero by means of the heart-piece 37.

The wheel 17 drives the hour shaft 39 through the intermediary of a coupling mechanism comprising a spring 40 pressing the wheel 17 against a shoulder 41a of a cannon 41 carried by the shaft 39 and also comprising a plate 42 movable axially by the effect of conical pins 43 carried by the sliding element 35. The shaft 39 carries the heart-piece 44 for resetting to zero. During disconnection, the wheel 17 is axially pressed against the endstone of the upper bearing of the shaft 39.

An elastic washer 45, having the shape of a four-armed star (Figures 2b and 5) is interposed between the wheel 17 and the bridge 4 of the frame of the mechanism, so as to produce friction on this wheel. Thus, when the several coupling devices of the mechanism are disconnected the wheel 5 is braked against the portion 2a of the plate 2, while the wheel 17 is braked by the spring 45, so that the whole gear train of the chronograph is then held at both its ends, which prevents any backlash of the gear wheels of the chronograph gear train.

The control mechanism of the function of the chronograph is shown principally in Figure 1. This mechanism comprises a rocking lever 46 for starting and stopping the chronograph pivoted at 47 on the frame, and on which one acts according to the arrow 48

by means of a pusher, not shown, carried by the casing of the watch.

This rocking lever 46 carries articulated thereon by means of a circular portion 49a, a finger 49 submitted to the action of a spring 50 provided with heel 50a pivoted at 51 on the frame of the movement. The heel 50a carries a pin 52 passing through a hole 53 provided in the sliding element 29 previously disclosed. The sliding element 29 occupies one or the other of its two working positions respectively shown in Figures 1 and 4, in each of which it is maintained by a jumper 54. The spring 50 also occupies one or other of two positions, under the effect of the edges of the hole 53 acting on the pin 52 in one of which positions it maintains the finger 49 opposite a portion 29a of the sliding element and in the other of which it maintains this finger opposite a reversing lever 55 pivoted at 56 on the frame of the movement and which is provided with a portion 55a engaged in a slot 57 of the sliding element 29. Thus, whatever the position occupied by the sliding element, the pressure exerted at 48 on the rocking lever 46 brings the sliding element into its other position, the finger 49 acting either directly on the sliding element, by means of the portion 29a thereof, or indirectly through the intermediary of the reversing lever 55.

The sliding element 29 acts on the one hand on the control element 26 of the first coupling mechanism, carrying the conical pins 27, and on the other hand, by means of a finger 29b, on a locking lever 58 intended to lock the sliding element 35 which carries the control pins 36 of the second coupling mechanism and the control pins 43 of the third. This sliding element 35, which is operated by means of a second pusher, not shown, acting at 59, carries three other pins 60, 61 and 62 operating respectively three resetting to zero hammers 63, 64 and 65 which cooperate respectively with the heart-pieces 30, 37 and 44 for resetting the second, minute and hour indicators. The sliding member 35 is provided with a portion 35a operating a brake 66 intended to act, through its end 66a, on the portion of larger diameter I 8b of the shaft 18 for braking the shaft when the first coupling device is in the uncoupled position, but releasing the shaft during the resetting to zero operation. Owing to the locking member 58, the sliding member 35 of the resetting to zero mechanism can be operated only when the sliding member 29 for starting and stopping the chronograph occupies the position shown in Figure 4, corresponding to the stopped position.

Finally, it is to be noted that the watch comprises a small seconds hand. Not shown, carried by a wheel 67 (Figure 5) driven by the second wheel 19 by the intermediary of wheel 68.

WHAT WE CLAIM IS: —

1. A chronograph timepiece wherein the chronograph mechanism includes a chronograph gear train arranged to be driven by the gear train of the movement of the timepiece and provided, at its end connected to the gear train of the movement, with a coupling and braking device, working in synchronism and, near its other end with at least one further braking device. the arrangement being such that, while the

chronographic gear train is stopped and is disconnected from the gear train of the movement, the chronograph gear train is held at its respective ends by the braking devices.

2. A timepiece as claimed in claim 1 wherein the seconds indicator of the chronograph mechanism is connected to the chronograph gear train through the intermediary of a coupling device which disconnects the indicator, following which the mechanism of resetting to zero is able to be operated, so that the resetting to zero of the indicator can be effected without driving the chronograph gear train.

3. A timepiece as claimed in claim 2, wherein the coupling device of the seconds indicator is constituted by the coupling device situated at the driven end of the chronograph gear train, this coupling device being arranged to permit the simultaneous disconnection, from the driving gear train of the movement, of the first element of the chronograph gear train, and of the seconds indicator.

4. A timepiece as claimed in claim 1, wherein the coupling and braking device includes a control device for producing, in one of its working positions, the coupling of the first element of the gear train of the chronograph mechanism to the gear train of the movement and, in its second working position, the disconnection from the gear train of the movement and the braking of said element.

5. A timepiece as claimed in claim 4, wherein the coupling and braking device constitutes a mechanism comprising a driving and a driven wheel coaxial to each other and both loosely mounted on a common shaft, one of which wheel bears axially against a shoulder of the said shaft and is rotatably connected to the other wheel by the action of a spring means which acts on the other wheel and on a further shoulder of the shaft, and the control device being arranged to act on the spring means for axially moving the spring and the wheels such that operation of the control device produces displacement of the spring and wheels until the driven wheel is applied against an element which brakes said wheel, and releases the wheels from their rotatable connection.

6. A timepiece as claimed in claim 5, wherein the shaft carries the seconds indicator of the chronograph, and a braking device acts on this shaft when the chronograph gear train is stopped and is disconnected from the gear train of the movement so as to maintain in position the said indicator.

7. A timepiece as claimed in claim 5, wherein the driving wheel bears against the shoulder and said shoulder is frustoconical, and the driving wheel is provided with a corresponding surface cooperating with said shoulder.

8. A timepiece as claimed in claim 4 or claim 5, wherein the chronograph mechanism comprises at least one sliding member

provided with axially directed embossments, each provided with a conical surface and each located in a corresponding hole of a disc shaped member, which is

axially movable, constituting the control device of the coupling and braking device, so that, in one position occupied by the said sliding member, each embossment

is situated coaxially in a corresponding hole of the disc shaped member. the disc shaped member being then not displaced by the sliding member while, in the other position of the sliding member, the conical surfaces of the embossments act on the edges of the said holes for axially displacing the disc shaped member and thus produce the disconnection and the braking of said first element.

9. A timepiece as claimed in claim 8, in which the chronograph mechanism comprises three indicators for seconds, hours and minutes, respectively, each provided with a coupling device, and in which the chronograph mechanism includes two sliding members provided with embossments, one of which members acts on one of the coupling devices and the other of which acts on two of the coupling devices.

10. A timepiece as claimed in claim 9, wherein the sliding member acting on only one coupling device operates the coupling device situated at the driving end of the chronograph mechanism, and which serves also to disconnect the second indicator, while the sliding member acting on two coupling devices operates the coupling devices which disconnect the two other indicators, respectively of minutes and of hours, the first of the said sliding members being controlled by a starting and stopping pusher of the chronograph mechanism while the second of these rocking members is controlled by a resetting to zero pusher.

11. A timepiece as claimed in claim 10, wherein the second sliding member also operates resetting to zero heart-pieces of the indicators of the chronograph mechanism.

12. A timepiece as claimed in claim 11 wherein the second sliding member is submitted to the action of a locking member which is operated by the first sliding member in such a way that the second sliding member is released for operation only when the first sliding member occupies its position corresponding to the stopping of the chronograph mechanism.

13. A timepiece as claimed in claim 10, wherein the first sliding member is controlled by the starting and stopping pusher of the chronograph mechanism through the intermediary of a reversing device arranged such that two successive pressures exerted on this pusher move the said sliding member alternatively in opposite directions.

A timepiece as claimed in claim 13, wherein the reversing device comprises a finger articulated on a movable member which is operated by the starting and stopping pusher of the chronograph mechanism, this finger being acted on by a return spring the position of which varies with the position of the first sliding member, such that, in one position of the spring, corresponding to one position of the said first sliding member, the finger is located opposite a bearing surface of the said first sliding member, so that a pressure exerted on the starting and stopping pusher then causes the finger to operate directly the first sliding member while, in the second position of this sliding member, while, in the second position of this sliding member, the said finger is located opposite a reversing member, which acts on the said first sliding member, so that a pressure exerted then on the starting end stopping

pusher causes the finger to act on the said first rocking member via the reversing member, so that the displacement of the first sliding member is effected towards the exterior of the timepiece.

15. A chronograph timepiece substantially as herein described with reference to the accompanying drawings.

ARTHUR R. DAVIES,
Chartered Patent Agents.
27. Imperial Square. Cheltenham.
- and -
115, High Holborn.
London W.C.1.
Agents for the Applicants.

Printed for Her Majesty's Stationery Office by The Tweeddale Press Ltd., Bervick-upon-Tweed, 1975 Published at the Patent Office, 2 Southampton Buildings, London, WC2A 1AY, from which copies may be obtained.

1 412 340 COMPLETE SPECIFICATION
3 SHEETS
This drawing is a reproduction of
the Original on a reduced scale.
SHEET 1

FIG. 1

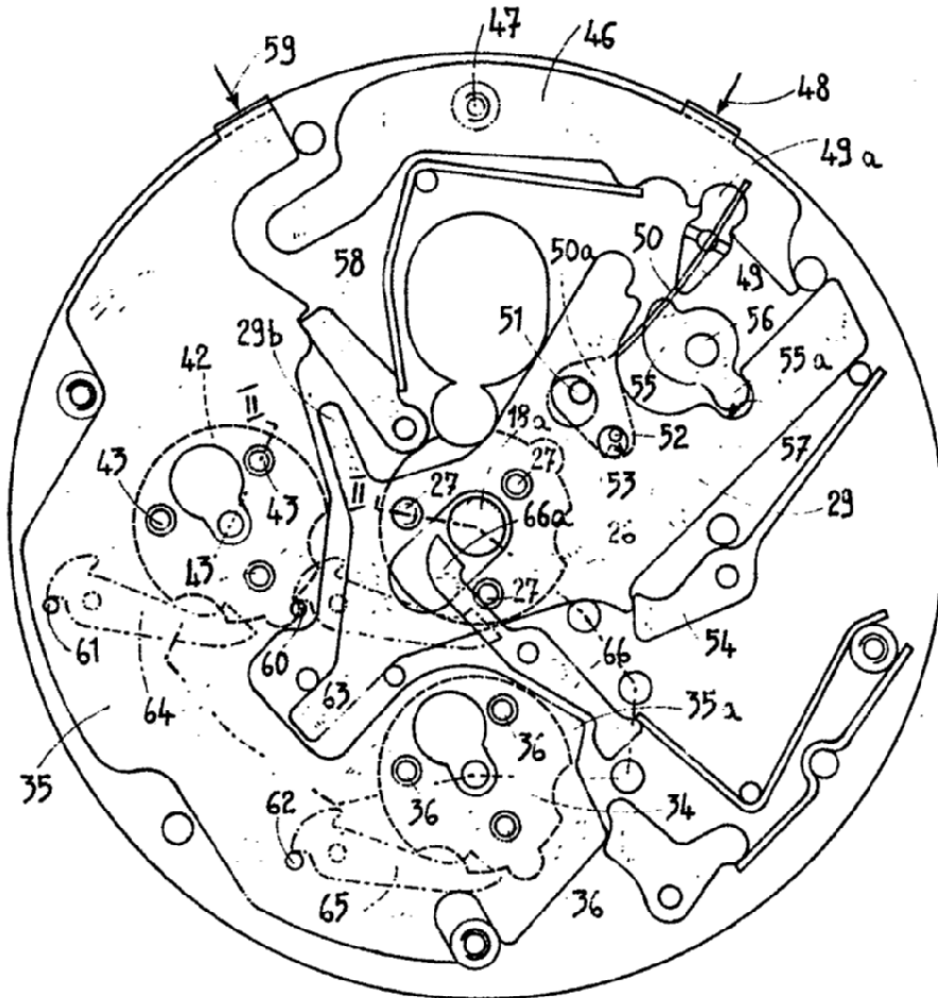
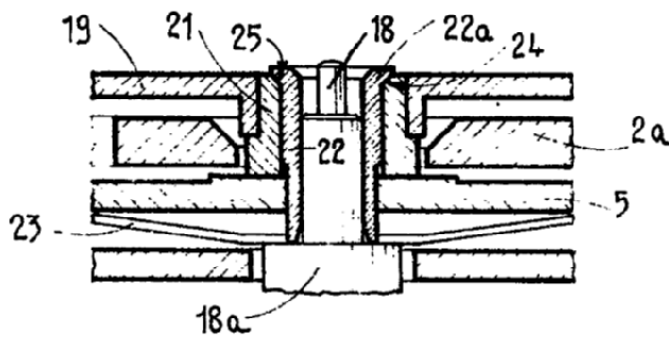

FIG. 3



1 412 340 COMPLETE SPECIFICATION

3 SHEETS

This drawing is a reproduction of the Original on a reduced scale.

SHEET 2

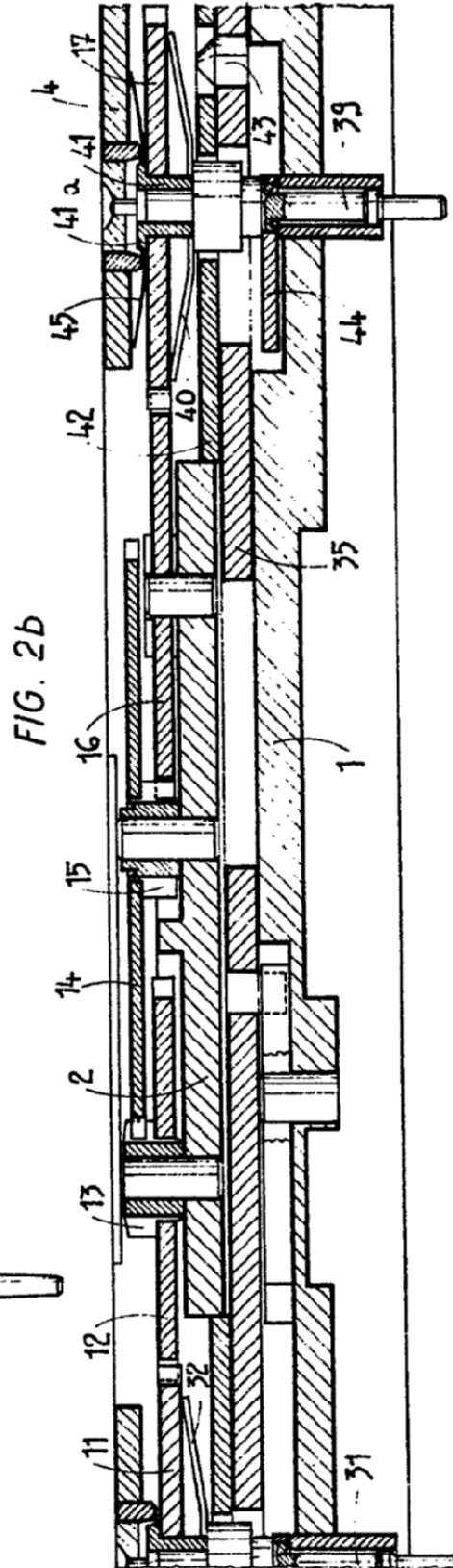
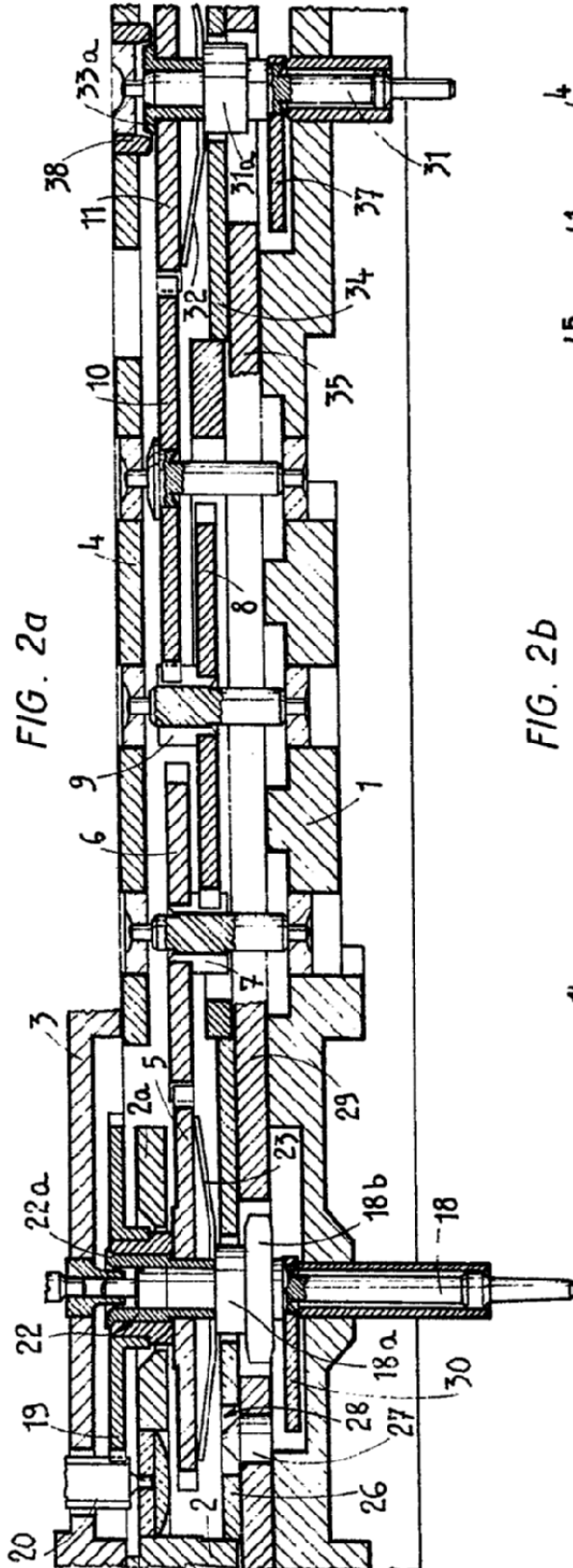

1 412 340 COMPLETE SPECIFICATION

3 SHEETS

This drawing is a reproduction of the Original on a reduced scale.

SHEET 3

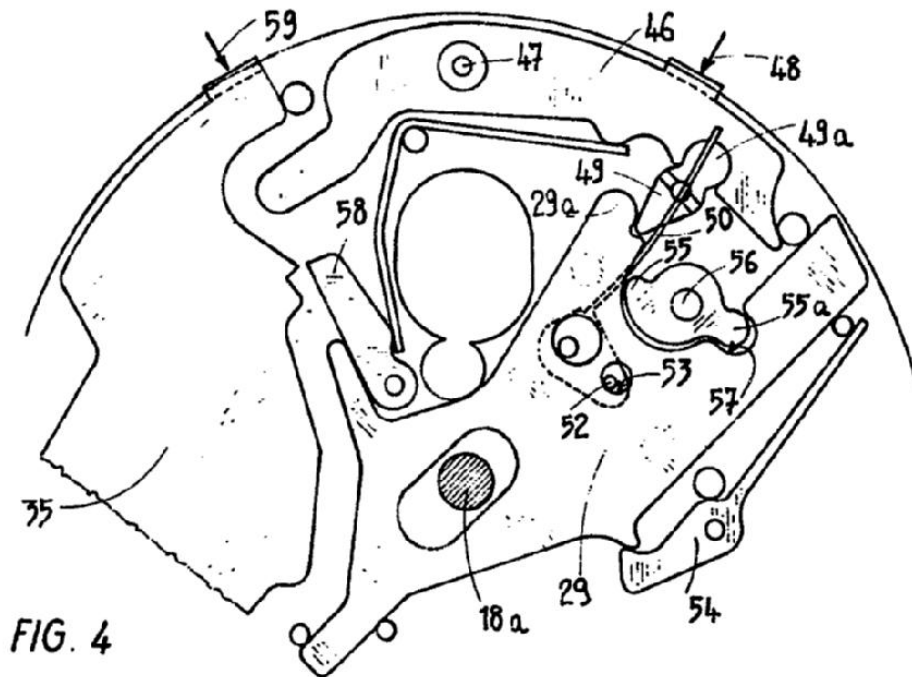

FIG. 4

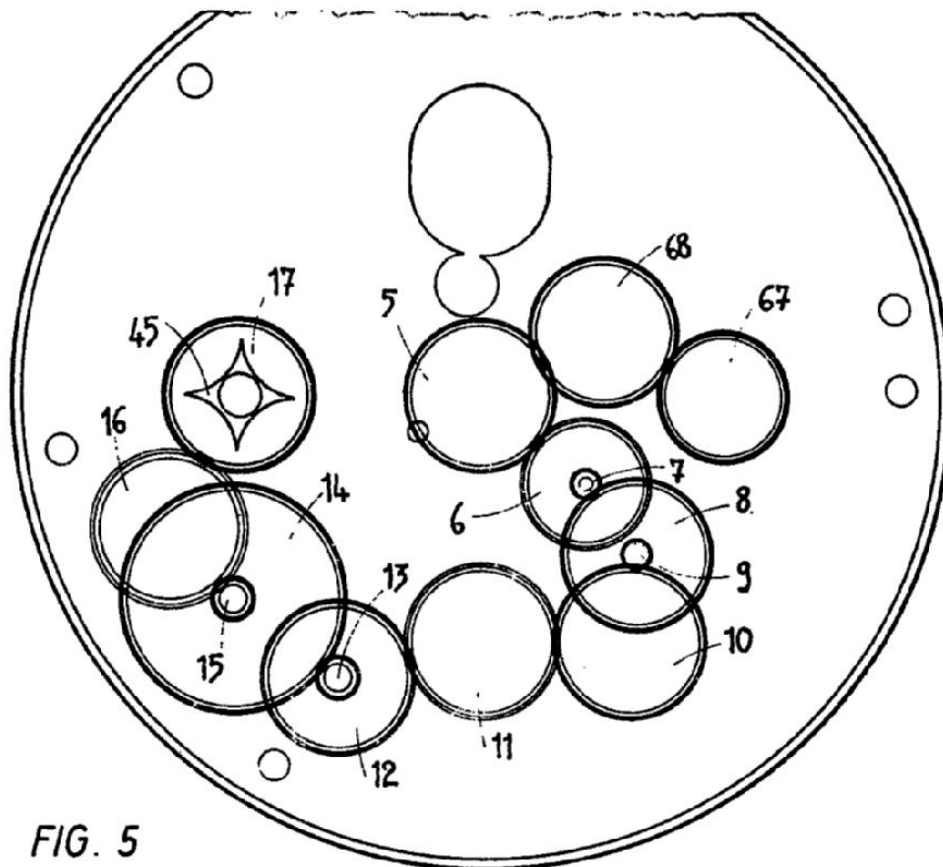

FIG. 5